



## HELIUM COMPRESSOR

**Model: QCLHeW**

## MANUAL

**October 2020**

#4-38936 Queens Way,  
Squamish, BC, V8B 0V2 CANADA  
Tel: +1-604-222-5539 Fax: +1-604-677-5826  
<http://www.quantum-technology.com>

PMB 183, 250 H Street  
Blaine, WA 98230, USA  
Tel: +1-888-271-9466 Fax: +1-888-711-5222  
[sales@quantum-technology.com](mailto:sales@quantum-technology.com)

[www.quantum-technology.com](http://www.quantum-technology.com)

## Contents

---

1. SAFETY .....	2
GENERAL.....	2
SPECIAL NOTICES .....	2
CAUTIONS .....	3
2. INTRODUCTION .....	4
3. PRINCIPLES OF OPERATION .....	5
4. DESCRIPTION.....	7
Components .....	7
5. SPECIFICATIONS.....	9
Electrical Characteristics .....	9
Environmental Requirements.....	11
Mounting position.....	11
Cooling Requirements .....	11
Water Quality Requirements.....	12
Helium Gas Pressures .....	12
Refrigerant Quality .....	13
Color Codes .....	13
Optional Spacing.....	13
Maintenance Intervals.....	13
Noise Level .....	13
Dimensions .....	13
Weight (approximately).....	13
General Operating Conditions .....	13
Supplier Name and Address.....	14
6. INSTALLATION .....	15
Introduction.....	15
Receipt Inspection Instructions.....	16
Unpackaging and Product Inspection Instructions .....	17
Compressor location .....	18
Compressor Voltage Selection.....	19
7. Troubleshooting Guide .....	30
8. APPENDIX.....	34

This manual and design contains confidential proprietary information that is the property of Quantum Technology Corp. This manual is supplied to the customer under the express understanding that it is to be used by the Customer for the operational and service purpose only and that it is not to be transmitted or distributed to third parties without written consent.

This manual may only be used on the customer's premises.

## 1. SAFETY

### General

Quantum Technology Corp. equipment is designed according to the national safety standards. The installation, operation and service are performed in accordance with the technical manual. You can find the information about Service Center in the service section of this manual.

### Special Notices

Three types of special notices -- WARNINGS, CAUTIONS and NOTES are used in this technical manual.

#### WARNINGS

WARNINGS pay attention to actions or conditions that can result in serious injury or death.

#### CAUTIONS

CAUTIONS pay attention to actions or conditions that can result in damage to the equipment or the abnormal performance.

#### NOTES

NOTES provide important, additional information to explain or suggest related problems or operations.

#### WARNINGS RELATED TO MAGNETISM

**AVOID INJURY.** When cryo-cooler is released in a high magnetic field, ferrous tools and parts can become hazardous projectiles. Do not use ferromagnetic tools when the magnet is in a magnetic field.

**AVOID EXPOSURE.** People with Cardiac Pacemakers, Defibrillators or Ferromagnetic Implants shall avoid exposure to strong field. Long-term effects of high magnetic fields have not been completely discovered. Shorten the personal exposure time in the magnetic field.

#### WARNING RELATED TO ELECTRICITY

**AVOID ELECTRIC SHOCK.** All electrical supply equipment must meet applicable codes and be installed by qualified personnel. Permit only qualified electrical technicians to open electrical enclosures, to perform electrical checks or to perform tests with the power supply connected and wiring exposed. Failure to observe this warning can result in serious injury or death.

This manual and design contains confidential proprietary information that is the property of Quantum Technology Corp. This manual is supplied to the customer under the express understanding that it is to be used by the Customer for the operational and service purpose only and that it is not to be transmitted or distributed to third parties without written consent.

This manual may only be used on the customer's premises.

## WARNINGS RELATED TO CRYOGENICS

**AVOID INJURY.** Extreme cold may cause frostbite. Do not touch any parts with frost while handling system components.

Do not splash cryogenic liquids on any areas of clothing or exposed skin; otherwise, skin tissue will get damaged. Always wear eye protection and gloves.

**AVOID ASPHYXIATION.** Keep the operation environment properly ventilated.

## GENERAL WARNINGS

**AVOID ELECTRIC SHOCK.** All electrical supply equipment must meet applicable codes and be installed by qualified personnel.

**AVOID INJURY.** Never use compressed helium gas from system without a proper regulator. Overpressure can cause serious injury if the system equipment ruptures.

Always wear eye protection when handling pressurized gas lines and other pressurized equipment. Never heat up the pressurized gas line or other pressurized components.

Disconnect gas lines only when the compressor is stopped. Disconnect the cold head while the gas returns to the room temperature. Material failure and uncontrolled pressure release might cause serious injury.

Please disconnect or connect a gas line coupling to avoid loosening the cold head or compressor coupling according to the QCLHEW compressor operating manual. Gas pressure can push the coupling with enough force to cause serious injury.

## CAUTIONS

**PRESERVE YOUR WARRANTY.** Modification to equipment without the consent of the manufacturer will void the warranty. Helium gas with a purity of 99.999% is required. The unqualified high purity helium gas can damage the system and warranty is invalid in this condition.

**PREVENT EQUIPMENT DAMAGE.** Only disciplined persons are permitted to install and remove the cold head.

Damage to gas lines can result from crimping by repeated bending and repositioning.

If the QCLHEW compressor is wired for 380/400 ( $\pm 10\%$ ) V3~, 50Hz electrical service, connecting to a higher voltage may damage the control circuit. Similarly, if it is wired for 480 V3~, 60 Hz, it can be damaged by connecting to 380/400 ( $\pm DC10\%$ ) V3~.

**AVOID GAS LEAKS.** Check the gasket seal on the male half of each Aeroquip coupling. Be sure that the gasket seal is in place and the sealing surfaces both on the male and female halves are clean before connecting. Replace the gasket seal if it is damaged or missing. Keep the gas line couplings aligned when making or breaking a coupling connection. Leaks might occur due to the weight of the gas line or due to a sharp bend near the connection.

This manual and design contains confidential proprietary information that is the property of Quantum Technology Corp. This manual is supplied to the customer under the express understanding that it is to be used by the Customer for the operational and service purpose only and that it is not to be transmitted or distributed to third parties without written consent.

This manual may only be used on the customer's premises.

**AVOID A MALFUNCTION.** Do not allow air to get into the helium gas cryogenic system. Moisture from the atmosphere can seriously degrade the performance of coldhead and produce an abnormal noise so that the system can't work normally.

## 2. INTRODUCTION





The compressors are designed to deliver high-pressure, oil-free, helium gas to cryogenic refrigerators. Cold head cables are used with the compressor to supply electrical power to cold heads. Self-sealing gas couplings make connection or disconnection compressor and the components from the rest of the closed-cycle cryogenic refrigeration system easily.

Pressures are stated as gauge, not absolute. Pressure units are bar and pounds per square inch (psig). For reference:

1 bar = 14.5 psig

1 MPa = 10 bar.

Definition of Symbols used in this manual and on equipment:

Symbols	Definitions
	Mains Disconnect On
	Mains Disconnect Off
	Note
	Protective Earth (Ground)
	Dangerous Voltage
<b>V3~</b>	Volts, AC, 3 phase

*Figure 1 Symbols and Definition*

This manual and design contains confidential proprietary information that is the property of Quantum Technology Corp. This manual is supplied to the customer under the express understanding that it is to be used by the Customer for the operational and service purpose only and that it is not to be transmitted or distributed to third parties without written consent.

This manual may only be used on the customer's premises.

## 3. PRINCIPLES OF OPERATION

The compressor continuously collects low-pressure helium from the system return line. It compresses, cools and cleans the gas, then delivers it through the system gas supply line to the cold head. See Figure 2.

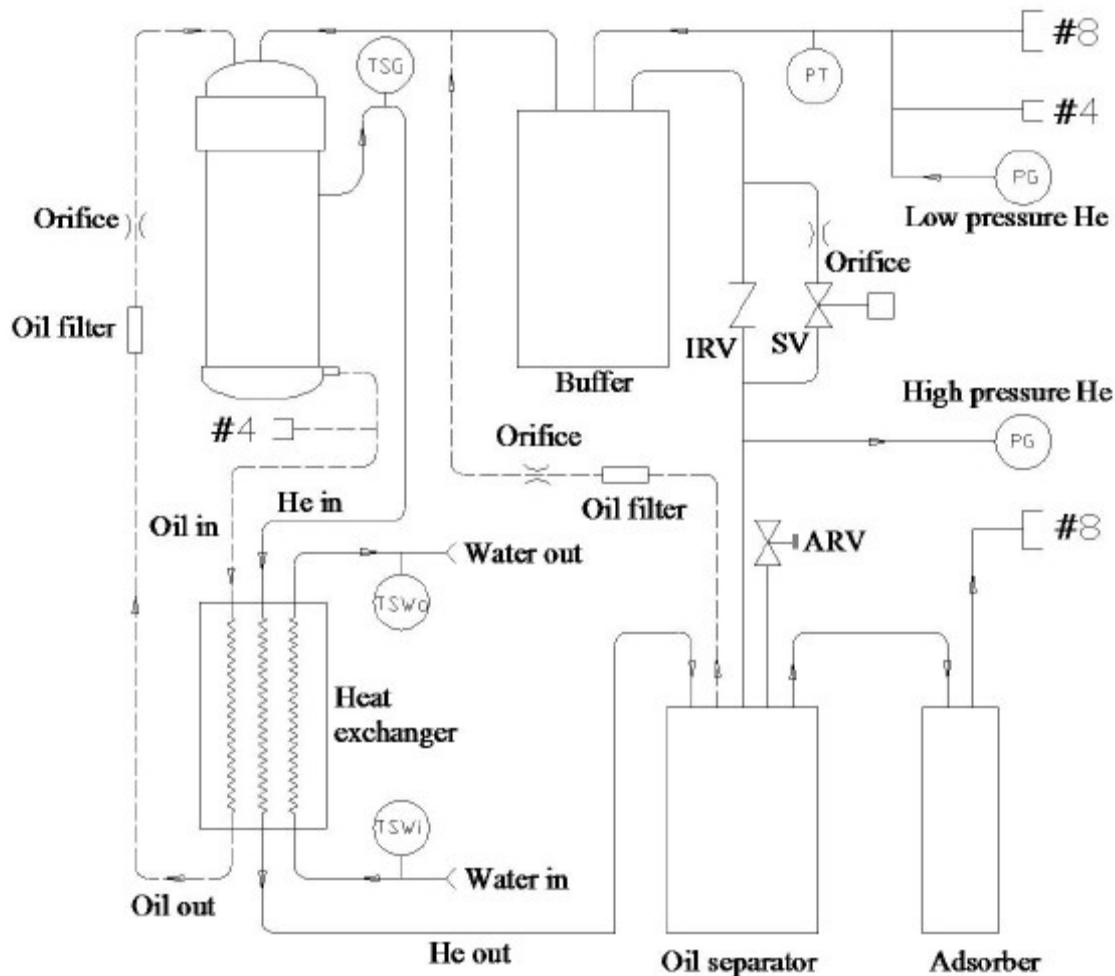

Figure 2 Compressor Flow Diagram

This manual and design contains confidential proprietary information that is the property of Quantum Technology Corp. This manual is supplied to the customer under the express understanding that it is to be used by the Customer for the operational and service purpose only and that it is not to be transmitted or distributed to third parties without written consent.

This manual may only be used on the customer's premises.

Key words:

Acronyms	Explanations
TSG	Gas temperature thermistor
TSWi	Water-in temperature thermistor
TSWo	Water-out temperature thermistor
ARV	Atmospheric relief valve
IRV	Internal relief valve
SV	Solenoid valve
PT	Pressure transducer
PG	Pressure gauge

Vertical compressor system includes an independent hydraulic system and pneumatic systems. After the oil and gas are discharged from the bottom of the compressor capsule, the high-pressure oil that is depressurized is injected into the low-pressure zone of the compressor capsule through the cooling heat exchanger and oil filter. The high temperature and pressure gas, via the heat exchanger and the oil separator, passes into the cold head. and then, the low-pressure gas returns back from the cold head to the compressor through the buffer tank.

The gas line includes an internal relief valve which is installed between two sides of high- and low-pressure gas. When the gas hose connection is not correct, the check valve will open to prevent the compressor motor overload.

Before entering into cold head, the gas is separated from oil through three stages. During discharging, the first stage process is accomplished by compressor's own function of gas-oil separation. The oil, passing through the separator, is condensed and returns back to the compressor because of the absorption of the gas mist of the material in the separator. This is the second stage. In the third stage, the gas is eliminated eventually after being absorbed by the absorber from the gas.

The oil is aggregated in the oil separator, and then returns back to compressor capsule through the orifice. The drive of the circulation of the oil in the system is the difference of gas pressure. The size of the orifice restricts the flow of bypass. A small amount of oil remains in the adsorber which can be replaced after a period of use.

The heat exchanger is a kind of water-cooled, plate-fin, counter-flow arrangement, heat exchanger. The cooling water is injected from the heat exchanger bottom. Reversely, the high temperature helium gas and oil are injected from the upper part of the heat exchanger.

This manual and design contains confidential proprietary information that is the property of Quantum Technology Corp. This manual is supplied to the customer under the express understanding that it is to be used by the Customer for the operational and service purpose only and that it is not to be transmitted or distributed to third parties without written consent.

This manual may only be used on the customer's premises.

## 4. DESCRIPTION

### Components

#### Helium Supply and Helium Return Pressure Couplings

Both supply (high pressure) and return (low pressure) are self-sealing, size 8, male (8M), Aeroquip, bulkhead couplings and are the points of connection on the front panel for the gas lines.

#### Helium Charge

A size 4, male (4M), Aeroquip coupling located on the front of the compressor is used for charging or venting helium gas refrigerant.

#### Water In and Out Fittings

QCLHEW is fitted with two (2) ½" MNPT.

#### Pressure Gauge

Indicates gas pressure in the supply line and gas return line. When the compressor is not running, the two (2) gauges are located on the compressor's front panel shows the equalization pressure.

#### Cold Head Power Receptacle

Mounted on the front panel for connecting a cable to supply electrical power from the compressor to the cold head.

#### Mains Power Switch

Mounted on the front panel, it provides a means to disconnect power and it protects the compressor from electrical overload. This device is labeled "Main Power".

#### Fuses

Three (3) (380/550V-GB13539) fuses, located inside the electrical chassis box, protect the overload of input circuit and transformer. Three (3) (250V/0.8A) fuses, located on the circuit, supply and protect cold head motor. 24V circuit uses resettable fuses (AHEF100/1A) to protect the circuit board.

#### Electrical Chassis

The electrical box contains electrical components and connections and distributes power to all system circuits.

This manual and design contains confidential proprietary information that is the property of Quantum Technology Corp. This manual is supplied to the customer under the express understanding that it is to be used by the Customer for the operational and service purpose only and that it is not to be transmitted or distributed to third parties without written consent.

This manual may only be used on the customer's premises.



## **Heat Exchanger**

Uses water to cool the high-pressure helium refrigerant and the compressor's lubricating oil.

## **Oil Separator**

Removes much of the entrained oil from the gas stream. This unit needs no servicing or replacement.

## **Adsorber**

The adsorber removes slight amount of oil and moisture in gas, which did not drop out in the separator. The adsorber has a finite life and must be replaced at regular intervals.

## **Internal Relief Valve [IRV]**

The internal relief valve opens to allow the compressor to be operated in the stand-alone mode or when the system gas lines are disconnected, it can avoid overloading the motor.

## **Oil Filter**

Filters in the oil lines ensure that the oil returning to the capillary and orifices is clean, and won't block the capillary and orifices.

## **Oil Orifice**

The orifice returns oil collected in the oil separator sump to the compressor for recycling.

## **Atmosphere Relief Valve [ARV]**

The pressure relief valve prevents the compressor from operating at an unsafe pressure by venting to the atmosphere.

## **Water High Temperature Thermistors**

Sense water temperature. One each is located in the "water in" line and in the "water out" line. They provide a warning if the inlet or the outlet water temperature is too high. High outlet water temperature indicates low water flow.

## **Compressor High Temperature Motor Protector Switch**

Located inside the compressor motor, the switch senses compressor motor temperature and stops the motor if the temperature is too high. The switch resets after cool down.

## **Supply Gas High Temperature Thermistor**

Senses discharge gas temperature. It causes the compressor to shut down if the temperature of the high-pressure helium from the compressor is too high.

## **Oil Injection Orifices**

These orifices are installed in the oil return lines and control the flow rate of oil returned to the compressor.

This manual and design contains confidential proprietary information that is the property of Quantum Technology Corp. This manual is supplied to the customer under the express understanding that it is to be used by the Customer for the operational and service purpose only and that it is not to be transmitted or distributed to third parties without written consent.

This manual may only be used on the customer's premises.

## 5. SPECIFICATIONS

### QCLHEW Compressor Details

Two (2) size 8M gas couplings; water-cooled; 380/400V ( $\pm 10\%$ ) V3~, 50 Hz or 480V ( $\pm 10\%$ ) V3~, 60 Hz.

### Electrical Characteristics

**Service required:** Delta connected, 4 wires (3 phase plus protective ground or earth). A screw-mounted, detachable connector is provided on the electrical front panel for connecting power to the compressor.

**QCLHEW Transformer Voltage Tap Selection:** The proper transformer voltage tap must be selected to match the incoming supply voltage. If not, open the transparent cover on the front panel, select the right input voltage.

<b>Power consumption:</b>	Gifford-McMahon (GM) Operation	Startup
<b>QCLHEW</b>	6.6 - 6.9 kW@50Hz 7.5 - 7.8 kW@60 Hz	< 8.5 kW@50Hz < 9.0 kW@60Hz

### Rated load current:

For the QCLHEW compressor, 13 amperes.

### Locked rotor current:

For the QCLHEW compressor, 90A@480V at 60Hz, 80A@400V at 50Hz.

### Internal circuit protection

Transformer: Three (3) (380/550V-GB13539)fuses, located inside the electrical chassis box, protect the overload of input circuit and transformer.

Cold head motor: Three (3) (little fuse 250V/0.8A) fuses, located on the circuit, supply and protect cold head motor.

Control circuit: Uses resettable (AHEF100/1A) fuses to protect the circuit board.

Fuses are located inside the electrical chassis box, for service by qualified electrical technicians only.

**Cold head power requirement:** 200 V3~, 0.53 amperes, supplied from the compressor.

**Cold head power supply:** A cable connects the cold head to the compressor.

### Class I: Grounded equipment

This manual and design contains confidential proprietary information that is the property of Quantum Technology Corp. This manual is supplied to the customer under the express understanding that it is to be used by the Customer for the operational and service purpose only and that it is not to be transmitted or distributed to third parties without written consent.

This manual may only be used on the customer's premises.

Compressor control logic provides:

- ON and OFF buttons for operation of the compressor and the cold head.
- Front panel LCD display of operating time.
- Push “DISPLAY” button to scroll the LCD display.
- Interlock to prevent starting the compressor and the cold head if the main power phase sequence is incorrect.
- Automatic restart of compressor after power interruption.
- Automatic shut off for the following system faults. Operator correction is required before press the “RESET” button.
  - High gas discharge temperature, when thermistor reads  $> 93^{\circ}\text{C}$  (5 automatic restarts at 20 minute intervals before operator correction required).
  - High compressor motor windings temperature, switch opens at  $160^{\circ}\text{C}$ , resets at  $69^{\circ}\text{C}$ .
  - High compressor motor current draw: QCLHEW trips at 14 amperes.
  - High cold head motor winding current, high solenoid valve motor current, open fuse(s).
  - Low gas return pressure,  $< 1.3\text{bar}$
- Error warning displayed for the following system faults, no automatic shutoff:
  - High water temperature,  $> 35^{\circ}\text{C}$
  - Low water flow, high water out temperature,  $> 46^{\circ}\text{C}$

See the Compressor Wiring Diagrams

### Front Panel Connections (See Figure 3)

- Helium gas connections: size 8, male (8M) Aeroquip couplings, high-pressure supply and low-pressure return.
- Helium fill port: size 4, male (4M) Aeroquip coupling.
- Cooling water connections: Swagelok bulkhead fittings,  $\frac{1}{2}$ ” MNPT.
- Mains power connector: Rectangular industrial connector
- Diagnostic interface connector: DB-25, for control and to indicate error condition.  
(See Definitions of Diagnostic Interface Connector of this manual)
- Serial connector: DB-9, for software upgrade, not for customer’s use.

### Front Panel Mounted Items (See Figure 3)

- Supply pressure gauge (0-40 bar, 0-600 psig)
- Return pressure gauge (0-40 bar, 0-600 psig)
- LCD display (to display compressor status)
- ON and OFF buttons
- DISPLAY buttons (to scroll the LCD display)
- RESET button (to reset errors)
- Main power switch
- Voltage selection access panel

This manual and design contains confidential proprietary information that is the property of Quantum Technology Corp. This manual is supplied to the customer under the express understanding that it is to be used by the Customer for the operational and service purpose only and that it is not to be transmitted or distributed to third parties without written consent.

This manual may only be used on the customer’s premises.

## Environmental Requirements

Item	Operating	Storage
Ambient Temperature	4-40°C	-20-62°C
Relative Humidity	30%-70%	10%-90% (non-condensing)
Magnetic Field Limits	≤50 Gauss	
Atmospheric Pressure	70kPa-110kPa	20kPa-110kPa

**NOTE** Operating the equipment out of specifications may void the warranty.

## Mounting position

Compressor must be mounted base down and level within 5 degrees of horizontal.

## Cooling Requirements

Application	Cooling water flow rate
4K GM and 10K GM Cold Head	6 to 9 L/min
Cooling water inlet temperature	5°C to 25°C
Cooling water outlet temperature	46°C maximum
Cooling water supply pressure	8 bar (116 psig) maximum
Pressure drop at 9L/min	<1 bar (<14.5 psig)
Alternative coolant	50% ethylene glycol + 50% water
Ethylene glycol/water (50/50) flow rate	7.8 to 11.7 L/min

For an installation using a water chiller or other circulating cooling system.

Use pure ethylene glycol with water for the coolant antifreeze solution. Do not use commercial ethylene glycol sold for automotive cooling systems, which usually contains a fine grit material that can damage the cooling system.

This manual and design contains confidential proprietary information that is the property of Quantum Technology Corp. This manual is supplied to the customer under the express understanding that it is to be used by the Customer for the operational and service purpose only and that it is not to be transmitted or distributed to third parties without written consent.

This manual may only be used on the customer's premises.

## Water Quality Requirements

Water supplied for cooling the compressor should be filtered through a 300-micron screen and meet the following quality limits:

Item	Initial Values for non-Replenished (closed) System	Values for Continuously Replenished (open) System
Suspended solids, µg/L	<250	<250
Particle size, µm	<300	<300
pH (25 °C)	6.5-8.0	6.0-8.0
Alkalinity (ppm)	100 max.	50 max.
Hardness (ppm)	200 max.	50 max.
Chloride (ppm)	200 max.	50 max.
Sulfate (ppm)	200 max.	50 max.
Iron (ppm)	1.0 max.	0.30 max.
Sulfur ion (ppm)	None detected	None detected
Ammonium ion (ppm)	1.0 max.	0.20 max.
Silica (ppm)	50 max.	30 max.

## Helium Gas Pressures

Application	Equalization Pressure at 20°C for 12 to 20 m long gas lines <sup>1</sup>	Operating (Supply) Pressure <sup>2</sup>	Operating (Return) Pressure <sup>2</sup>
4K GM Cold Head, 50/60 Hz	16.0-16.5 bar (16.0 bar nominal)	19.0-22.0 bar (276-319 psig)	4.0-6.0 bar (58-87 psig)
10K GM Cold Head, 60 Hz	13.5-14.0 bar (13.6 bar nominal)	16.6-20.7 bar (240-300 psig)	2.8-6.9 bar (40-125 psig)
10K GM Cold Head, 50 Hz	14.0-15.0 bar (14.3 bar nominal)	19.0-22.0bar (276-319 psig)	4.0-6.0 bar (58-87 psig)

- A. Under equalization pressure, the readings of high pressure gauge and low pressure gauge may be different because of error of pressure gauges. It is suggested to take high pressure gauge as preliminary preference.
- B. The supply and return pressure vary according to the heat load of cold head and ambient temperature.

This manual and design contains confidential proprietary information that is the property of Quantum Technology Corp. This manual is supplied to the customer under the express understanding that it is to be used by the Customer for the operational and service purpose only and that it is not to be transmitted or distributed to third parties without written consent.

This manual may only be used on the customer's premises.

## Refrigerant Quality

Refrigerant is 99.999% pure helium gas with a dew point temperature less than  $-50^{\circ}\text{C}$  at 20.7 bar.

**CAUTION PRESERVE YOUR WARRANTY.** Specifications require the use of 99.999% pure helium gas. Using a lesser quality of helium can damage the system and void the warranty.

## Color Codes

- SUPPLY (red) - Helium high-pressure gas supply from the compressor to the cold head.
- RETURN (green) - Helium low-pressure gas return to the compressor from the cold head.

## Optional Spacing

Allow 600 mm space in front of the compressor for access to electrical, water and gas connections. Allow 600 mm space on the left side (when facing the front) of the compressor for maintenance of the adsorber.

## Maintenance Intervals

Compressor adsorber: 27,000 operating hours (3 years)

## Noise Level

<70 dB(A) at 1m

## Dimensions

See Figure 4. Three removable eyebolts are furnished for lifting.

## Weight (approximately)

Compressor: 107 kg

## General Operating Conditions

Normal pressure and temperature data are listed above. User should record monthly the operating conditions in a logbook. Keep this record of data for reference and later comparisons.

This manual and design contains confidential proprietary information that is the property of Quantum Technology Corp. This manual is supplied to the customer under the express understanding that it is to be used by the Customer for the operational and service purpose only and that it is not to be transmitted or distributed to third parties without written consent.

This manual may only be used on the customer's premises.

## Supplier Name and Address

Quantum Technology Corp.

#4 – 38936 Queens Way

Squamish, B.C., V8B 0V2, CANADA

Tel: +1-604-222-5539 Fax: +1-604-677-5826

Toll Free: +1-888-271-9466 Fax: +1-888-711-5222

[quantum@quantum-technology.com](mailto:quantum@quantum-technology.com)

## Application of Q/320115 NJKD01-2011 Standard

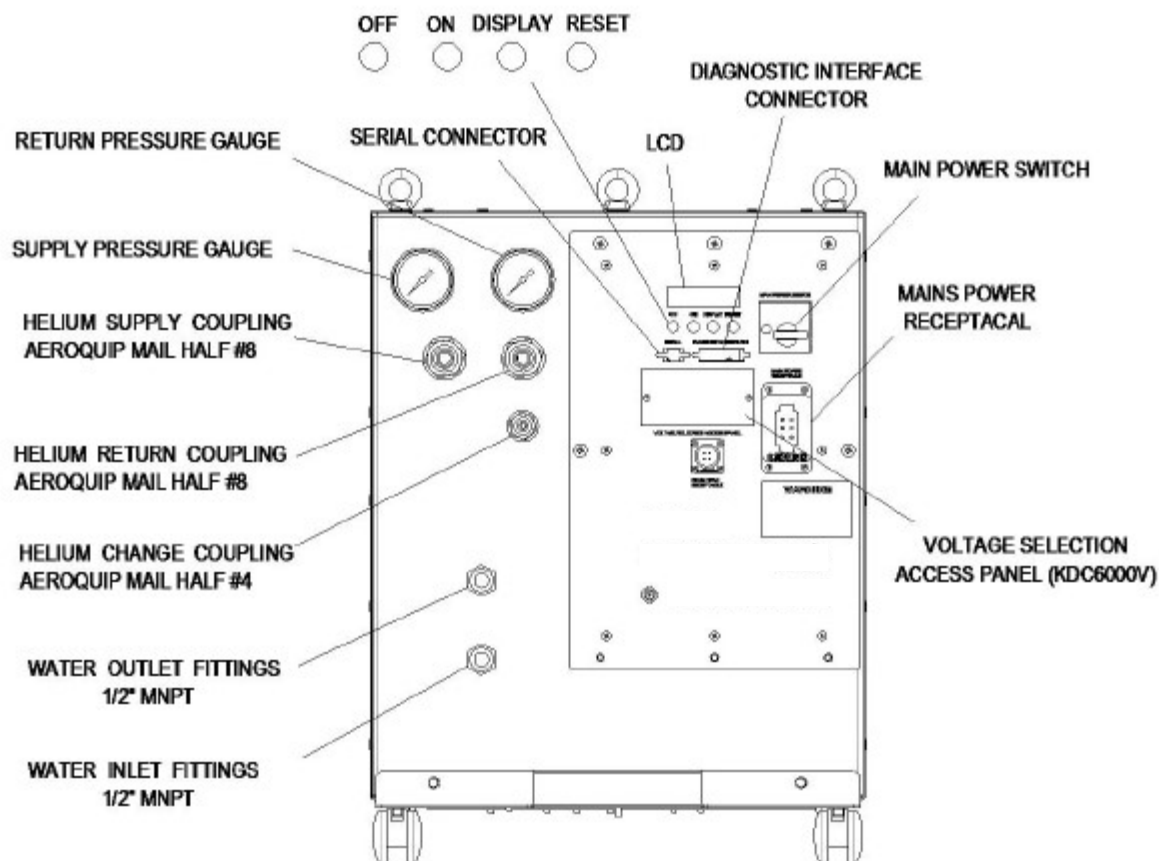

*Figure 3 QCLHEW Compressor, Front View*

This manual and design contains confidential proprietary information that is the property of Quantum Technology Corp. This manual is supplied to the customer under the express understanding that it is to be used by the Customer for the operational and service purpose only and that it is not to be transmitted or distributed to third parties without written consent.

This manual may only be used on the customer's premises.

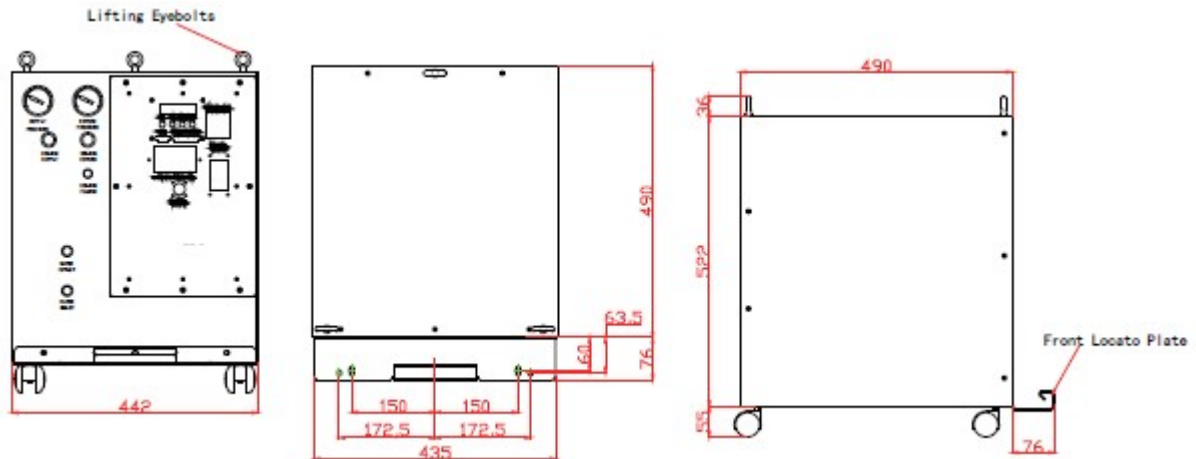

Figure 4 QCLHEW Compressor, Dimensions(mm)

## 6. INSTALLATION

### Introduction

Installing the QCLHEW Compressor, Cold Head Cable and the Gas Lines according to the following procedures. The following installation procedures are based on standard arrangements of equipment, using NCCT standard components.

To prevent contaminating the components or the system, it is important to follow the procedures in this manual step by step.

**NOTE** Be sure to have 99.999% pure helium gas available for installation of the system. See Refrigerant Quality in Specifications.

This manual and design contains confidential proprietary information that is the property of Quantum Technology Corp. This manual is supplied to the customer under the express understanding that it is to be used by the Customer for the operational and service purpose only and that it is not to be transmitted or distributed to third parties without written consent.

This manual may only be used on the customer's premises.



## Receipt Inspection Instructions

- 1.1. Upon receipt, inspect the shipping container and the compressor for damage.

**CAUTION AVOID EQUIPMENT FAILURE, CONTAMINATION OR A NUISANCE SHUTDOWN.** Do not tip the compressor more than 5 degrees from horizontal to avoid flowing oil into unwanted places.

**CAUTION AVOID CONTAMINATION.** When checking the compressor for shipping damage, do not connect gas lines and cold head. The components may become contaminated with compressor oil.

- 1.2. If there is any evidence of external damage to the container, be sure the carrier's driver sees the damage. Note it on the shipping documents and have the driver acknowledge it by his initials on the delivery receipt.
- 1.3. Remove the compressor from its shipping container and inspect for damage. If there was external damage to the compressor, remove its covers and check for internal damage. Notify the carrier immediately and take photographs of the damage to document your claim to the carrier. Keep the damaged shipping container.

**NOTE** Retain the shipping containers, if reusable, for returning the components to the factory if reconditioning is required. If internal damage is suspected, retain the shipping container for proof to the carrier.

### 2 Inspect for Proper Charge Pressure

- 2.1 The Charge Pressure of the Compressor Unit can be checked from the outside of the shipping container without removing the packaging.
- 2.2 Look through the "peep hole" on the container. View the pressure gauge on the Compressor Unit front panel. The pressure gauge should indicate 232-239 psig (16.0~16.5bar) at 20°C.
- 2.3 If the gauge indicates 0 psig (0 bar), the Compressor Unit cannot be used. Contact the supplier.

### 3 Upon receipt, inspect Tip-N-Tell Sensor on Package for Activation

- 3.1 The Tip-N-Tell sensor mounted on the shipping container package surface should be checked upon receipt and before unpackaging to verify the "Compressor Unit shipping container" was NOT tipped during transport.
- 3.2 If activated, Tip-N-Tell sensor doesn't turn red in the arrow as shown below. Proceed with internal inspection. If the sensor turns red, notify the carrier immediately and take photographs of the tip to document your claim to the carrier.

This manual and design contains confidential proprietary information that is the property of Quantum Technology Corp. This manual is supplied to the customer under the express understanding that it is to be used by the Customer for the operational and service purpose only and that it is not to be transmitted or distributed to third parties without written consent.

This manual may only be used on the customer's premises.



**NOT TIPPED (GOOD)**



**TIPPED (NOT GOOD)**

## Unpackaging and Product Inspection Instructions

1. Unpackaging Instructions
  - 1.1. Remove the straps around the package.
  - 1.2. Remove the Packaging Cover Shell and Inside Cushions.
  - 1.3. Put down the side board, place on end on the flat floor, and insert the sealing bar in the container into the gap between the floor and slope.
  - 1.4. Hold the compressor steadily, and pull it out of the package along the track slowly.
  - 1.5. Retain the reusable shipping container parts for possible reuse. This includes the wooden base, cushion blocks, cushion sealing bars, and etc.
2. Inspect the Tip-N-Tell Sensor on Compressor Unit for Activation.
  - 2.1. Check the Tip-N-Tell sensor mounted on the compressor rear panel. If the Tip-N-Tell sensor shows no mishandling and there is no apparent physical damage, skip Steps 2.2 and 2.3 and proceed to the section Compressor Location.

This manual and design contains confidential proprietary information that is the property of Quantum Technology Corp. This manual is supplied to the customer under the express understanding that it is to be used by the Customer for the operational and service purpose only and that it is not to be transmitted or distributed to third parties without written consent.

This manual may only be used on the customer's premises.



NOT TIPPED(Good)



TIPPED(Not Good)



## 2.2 The equalization pressure is within specifications:

If the compressor has been momentarily tipped (less than one hour) and the equalization pressure is within specifications, allow it to stand upright for two hours before performing this step.

Connect power and water to the compressor. See the next sections Compressor Location, Electrical Supply Connection, Coolant Connections. Test run the compressor for two (2) hours minimum. If there are no problems during this time, stop the compressor and proceed to assemble the system.

If the compressor malfunctions during the two (2) hour test, contact the supplier.

## 2.3 If the equalization pressure is outside the specified range or there is physical damage to the compressor enclosure or the compressor has been on its side or upside down for an extended period of time (more than one hour), contact the supplier and notify the delivering carrier of the damage.

NOTE: When checking the compressor for shipping damage, do not connect gas lines and cold head. The components may become contaminated with compressor oil

## 3. Inspect for Visible Damage of Compressor Unit.

3.1 Inspect the exterior panels of the Compressor Unit for evidence of damage.

3.2 If there was external damage to the compressor, remove the compressor unit panels and check for internal damage. Notify the carrier immediately and take photographs of the damage to document your claim to the carrier.

3.3 If any irrecoverable damage is found (e.g. oil Leakage, panel deformation), contact the supplier.

## Compressor location

Place the compressor in a location that is protected from the elements and where the ambient temperature will always be within the range of 4°C to 40° C.

The compressor must be installed base down, within 5 degrees of horizontal, and preferably at a height convenient for making connections and reading the pressure gauge.

Allow 600 mm space in front of the compressor for access to electrical, water and gas connections. Allow 600 mm on the left side (when facing the front) of the compressor for maintenance of the absorber

This manual and design contains confidential proprietary information that is the property of Quantum Technology Corp. This manual is supplied to the customer under the express understanding that it is to be used by the Customer for the operational and service purpose only and that it is not to be transmitted or distributed to third parties without written consent.

This manual may only be used on the customer's premises.

## Compressor Electrical Control Panel



Figure 5 Electrical Control Panel

## Compressor Voltage Selection

The Compressor is factory set for 380 V3~. L1, L2, L3, G are connected to A phase, B phase, C phase and ground respectively. If the LCD displays Phase seq: Err after the power is connected it means your input phase sequences are not right. Interchange any two adjacent phases. Before power is supplied, the following procedure must be applied:

1. Disconnect the mains power supply to the compressor.
2. Remove the clear plastic cover at the voltage selection access panel on the front of the compressor.
3. Move the exposed connector to the voltage tap connector labeled for the correct supply voltage. If the voltage needs to be adjusted, qualified technicians shall read the manual thoroughly, or contact the supplier, see Figure 6.
4. Replace the clear plastic window.
5. Reconnect the compressor's main power.

This manual and design contains confidential proprietary information that is the property of Quantum Technology Corp. This manual is supplied to the customer under the express understanding that it is to be used by the Customer for the operational and service purpose only and that it is not to be transmitted or distributed to third parties without written consent.

This manual may only be used on the customer's premises.

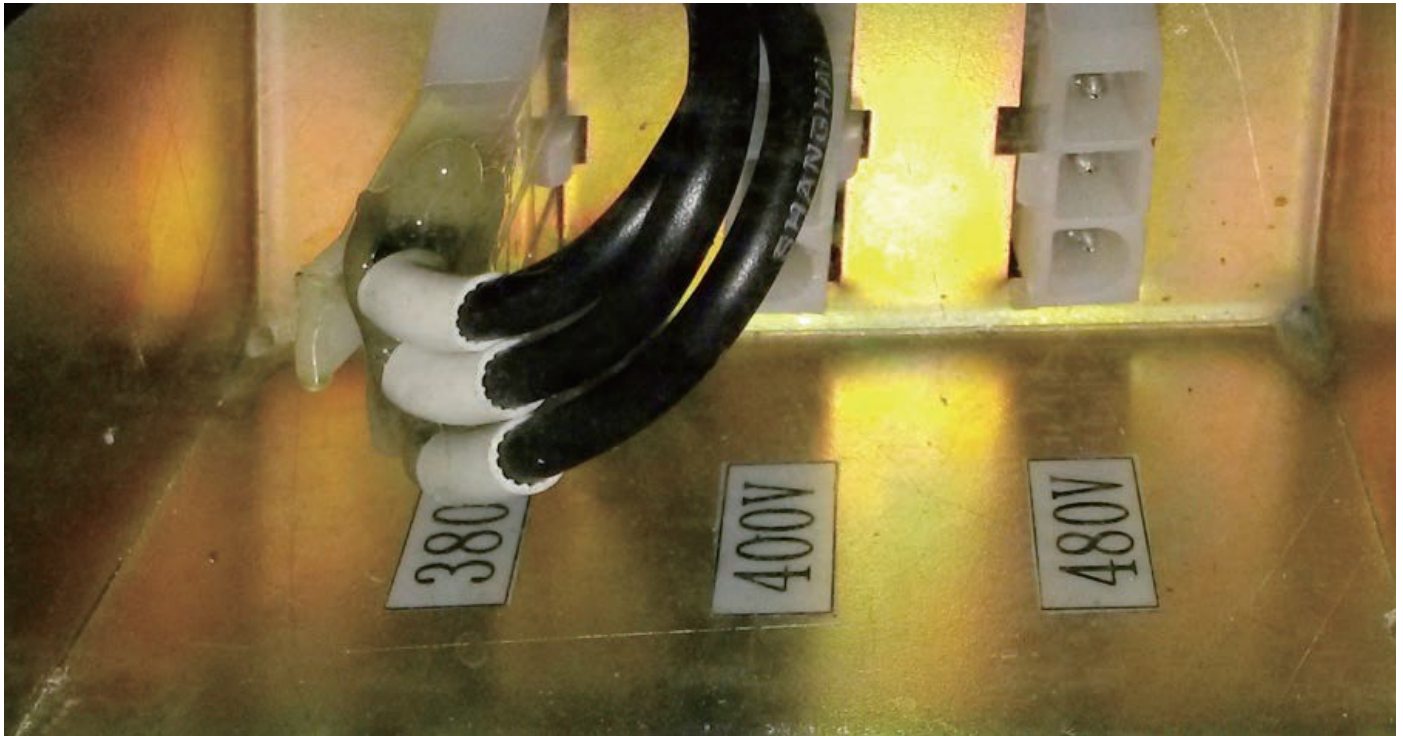

*Figure 6 Voltage Selection*

**CAUTION: PREVENT EQUIPMENT DAMAGE.** If the Compressor is wired for 380/400 V3~, 50 Hz electrical service, connecting it to a higher voltage may damage the control circuit. Similarly, if it is wired for 480 V3~, 60 Hz, it can be damaged by connecting to 380/400 V3~.

## Supply Connection

The Compressor must be installed in a circuit capable of supplying the specified voltage and power. The wiring method used for connection to the front panel power connector must meet applicable codes. Male joint and female joint shall be matched.

Connect mains power supply cable into the mains power receptacle (see Figure 7) on the front panel and fasten cover with attached screws. See Figure 8.

This manual and design contains confidential proprietary information that is the property of Quantum Technology Corp. This manual is supplied to the customer under the express understanding that it is to be used by the Customer for the operational and service purpose only and that it is not to be transmitted or distributed to third parties without written consent.

This manual may only be used on the customer's premises.

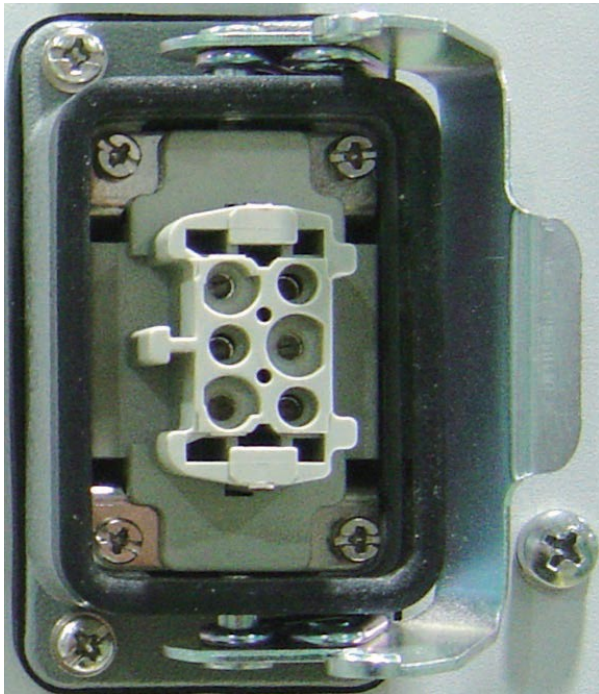

*Figure 7 Mains power receptacle*



*Figure 8 Connect mains power supply cable to mains power receptacle*



*Figure 9 Main Power Switch*



*Figure 10 Button Display*

This manual and design contains confidential proprietary information that is the property of Quantum Technology Corp. This manual is supplied to the customer under the express understanding that it is to be used by the Customer for the operational and service purpose only and that it is not to be transmitted or distributed to third parties without written consent. This manual may only be used on the customer's premises.



*Figure 11 LCD Display*



*Figure 12 Cold Head Motor Socket*



*Figure 13 Connect and Remove the Water Lines*

## Coolant Connections

Wrap the "water in" and "water out" thread (1/2" MNPT) on the front panel of the compressor with tapes. Use two open-end wrenches to connect coolant supply and return lines to the water in and water out fittings on the front of the compressor. See Figure 13. Ensure that the Water In connection is connected to the supply line from the user's cooling water or coolant supply. Turn on the coolant and check the water lines for leaks. Tighten the fittings if necessary. Please strictly refer the water quality requirements in the manual, special the chlorine content, excess may cause the heat exchange to be corroded.

## Compressor Checkout

The compressor should be operated before being connected to the other system components.

1. For the QCLHEW Compressor, be sure that the transformer voltage taps are correctly selected to match the supply voltage.

This manual and design contains confidential proprietary information that is the property of Quantum Technology Corp. This manual is supplied to the customer under the express understanding that it is to be used by the Customer for the operational and service purpose only and that it is not to be transmitted or distributed to third parties without written consent.

This manual may only be used on the customer's premises.

2. Supply power to the compressor. Set the compressor's Main Power switch to on. Push the ON button. Run the compressor for ten (10) minutes and then stop.
3. While the compressor is running, lightly touch the water supply and return lines. The return (water out) line should be warmer. If the return water line is cooler than the supply (water in) line, stop the compressor and reverse the water connections.

NOTE: The compressor has reversed-phase protection to prevent it from running in reverse. If it does not start and the LCD displays "EASYCOOL/Phase Seq:ERR", disconnect the power and interchange any two mains supply wires (except ground). Refer to the Troubleshooting section in this manual.

If the compressor starts but does not build pressure, turn it off immediately. It could be running in reverse despite the above-mentioned phase monitor relay. Contact the supplier if this occurs.

## Install the Gas Lines

Tool required: Open-end wrenches, 1", 1/8", 1 3/16"

Gas lines are shipped with protective dust plugs. Do not remove the plugs until the gas lines are ready to be attached. All bending and routing of gas lines should take place with plugs in place.

1. Identification labels are furnished with the gas lines. Before installing the gas lines, identify each with an appropriate label, SUPPLY (high pressure, color-coded yellow) or RETURN (low pressure, color-coded green) by applying the label adjacent to each coupling. See Figure 14.

2. Arrange the system components so that the gas lines will be protected from stress and traffic.

Observe the minimum bend radius of 180 mm when routing gas lines. Provide supports where needed.

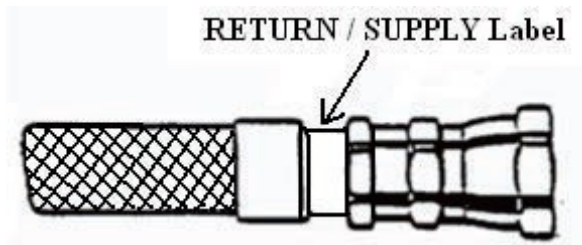

Figure 14 Attach identification label

3. Remove the dust caps from the compressor's supply and return gas couplings. Retain the dust caps and plugs to re-cover the couplings when they are not in use. Connect the gas lines to the compressor's supply and return couplings. Use two wrenches to tighten the coupling.

Torque all couplings to  $47 \pm 7$  Nm. See Figure 15. Tighten each coupling before proceeding to the next one.

This manual and design contains confidential proprietary information that is the property of Quantum Technology Corp. This manual is supplied to the customer under the express understanding that it is to be used by the Customer for the operational and service purpose only and that it is not to be transmitted or distributed to third parties without written consent.

This manual may only be used on the customer's premises.



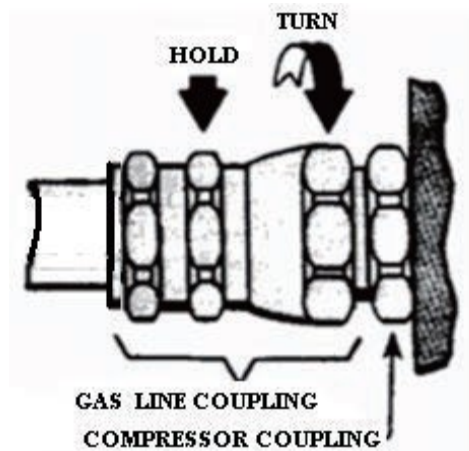

Figure 15 Gas line connections

**WARNING:** Always wear eye protection when handling pressurized gas lines and other pressurized equipment. Never apply heat to a pressurized gas line or other pressurized components.

**CAUTION:** Damage to gas lines can result from crimping by repeated bending and repositioning. Check the condition of the gasket seal on the female half of each coupling. Be sure the gasket seal is in place and the sealing surfaces are clean before connecting. Replace the gasket seal if it is damaged or missing. Keep the gas line couplings aligned when making or breaking a coupling connection. Leaks can occur due to the weight of the gas line or due to a sharp bend near the connection.



**NOTE:** Be sure to have 99.999% pure helium gas available at the installation site in case gas needs to be added to the system. See Refrigerant Quality in Specifications in this manual.

This manual and design contains confidential proprietary information that is the property of Quantum Technology Corp. This manual is supplied to the customer under the express understanding that it is to be used by the Customer for the operational and service purpose only and that it is not to be transmitted or distributed to third parties without written consent.

This manual may only be used on the customer's premises.

## Adjust System Equalization Pressure

When the compressor is at room temperature of 20°C, check if its equalization pressure is at a constant value. If the compressor is set on equalization pressure the pressure changes slightly according to a temperature changes. If the pressure deviates from the specified range, the gas supply may be connected wrong, or gas leaks.

1. Check all the gas lines connecting the compressor and clod head according to the system schematic diagram.
2. Connect power to the compressor. Switch the compressor mains power to ON. Do not start the compressor.
3. Press DISPLAY. The display on front panel shows EASYCOOL/Rtn press:xxx. Check the return pressure.
4. Check if the values displayed are in the specified range and the system temperature is 20°C,.
5. If the pressure is too high, following tools are required:
  - charge, a size 4, valve, female Aeroquip coupling 5/8"and 3/4"flat wrenches
  - 5.1 Check the compressor has stopped and temperature stays at 20°C.
  - 5.2 Make sure the valve on the charge is closed. Use two wrenches to connect the adapter to the #4 male Aeroquip coupling.
  - 5.3 Slowly opens the adaptor valve, vent all the helium in the system. Close the valve when required pressure is reached.
  - 5.4 Use the two wrenches to take the adaptor off.
6. If the pressure is too low, following tools are required:
  - charge, a size 4, valve, female Aeroquip coupling, 5/8"and 3/4"flat wrenches, Helium bottle, Relief valve, Gas line
  - 6.1 Stop the compressor.
  - 6.2 Install a charge, and open the valve slowly. Use two wrenches to connect the adapter to the #4 male Aeroquip coupling. Close the valve.
  - 6.3 Connect the helium gas line to the helium bottle with 99.999% purity of helium with temperature minus 50°C at 20.7bar.
  - 6.4 Clean the gas line thoroughly when connecting the gas line to the charge. Open the relief valve slightly; allow some gas to clean the gas line. At the same time, slightly open the valve on the charge, release some gas in the compressor, clear the remaining gas at the charge connector. Then both the gas line and the charge are cleaned. Connect these two parts without closing the valve and relief, then close the charge valve. It is critical to remove all the impurities out of the system.
  - 6.5 Adjust the relief valve to equalize the pressure. See the specifications.Slightly open the valve on the charge. Fill in the helium to reach system equalization pressure.
  - 6.6 Close the relieve valve on the charge and gas bottle.
  - 6.7 Remove the gas line and charge. Keep the gas line clean and store it.

This manual and design contains confidential proprietary information that is the property of Quantum Technology Corp. This manual is supplied to the customer under the express understanding that it is to be used by the Customer for the operational and service purpose only and that it is not to be transmitted or distributed to third parties without written consent.

This manual may only be used on the customer's premises.

## Install the Cold Head Cable

1. Be sure the compressor is not running by pressing the OFF button.
2. Connect the cold head cable to the cold head cable receptacle on the compressor front panel. Connect the other end of the cable to the electrical receptacle on the cold head.

## Diagnostic Interface Connector

Tool required: Small, flat blade screwdriver A DB-9 connector is located on the front panel of the compressor for software update. A DB-25 connector is located on the front panel for remote control and to supply remote indication of the operating status of the compressor. See Figure 16.

NOTE: The DB-25 pin assignments are shown in the Appendix Section of this manual.



Figure 16 DB-9 Software Update Connector and DB-25 Remote Connector

## Prestart Check

1. Check that the cooling water lines are connected and that the supply is connected to the water in connection. Turn on the coolant and check the lines for leaks. Tighten the fittings if necessary.
2. Check that all electric connections are made:
  - a. Power to the compressor
  - b. Cold head cable
  - c. Diagnostic interface cable (if used)
3. Check that the electrical power supply is switched on. Check that the equalization pressure is as specified when the compressor is at room temperature (20° C).

## Starting

Supply power to the compressor. Turn the knob of the main power switch on the front of the compressor to ON. Push the ON button on the compressor's front panel. The output voltage from the compressor to the cold head interface is 200 V<sub>3~</sub>.

**CAUTION:** After starting the system for the first time, to be certain that the water lines are properly connected, check that the outlet water temperature is warmer than the inlet water.

This manual and design contains confidential proprietary information that is the property of Quantum Technology Corp. This manual is supplied to the customer under the express understanding that it is to be used by the Customer for the operational and service purpose only and that it is not to be transmitted or distributed to third parties without written consent.

This manual may only be used on the customer's premises.

## Stopping

Push the OFF button. The compressor and the cold head will stop. The output voltage of 200 V3~ from the compressor to the cold head interface stops.

## Cold Head Run Only

For running the cold head only to perform a maintenance procedure, the cold head receptacle can be energized to 200 V3~ without running the compressor by:

1. While the system is off, press DISPLAY, scroll the display until “COLD HEAD RUN/YES-ON;NO-OFF” is shown.
2. While “COLD HEAD RUN/YES-ON;NO-OFF” is displayed, press the ON button. Wait for about 10 seconds. If it doesn't return to the main interface “EASYCOOL V1.2”, only the cold head run is started. Check the cold head motor to make sure it is running. The cold head will run until the OFF button is pressed or until 30 minutes of running has occurred.

## Restarting after a Power Failure

When the power comes on, the microprocessor will determine if the last shutdown was due to a power outage. If the compressor power was interrupted by a power outage, the compressor and the cold head will restart automatically a few seconds after power is restored. If the compressor stops for other reasons, the LCD will show the specific problems.

## Automatic Restart After a Helium High Temperature Shutdown

If a helium discharge high temperature shutdown error causes a shutdown of the system, the compressor will attempt to restart itself 5 times in 20 minute intervals before a reset signal must be provided to the compressor. A power outage will clear the shutdown error and reset the automatic restart counter.

## System Status Display

Normal conditions: If there are no system errors, the following lines are displayed on the LCD after pressing “DISPLAY”

EASYCOOL/Ads time:xxx  
EASYCOOL/Phase seq:OK  
EASYCOOL/Helium temp:OK  
EASYCOOL/Water temp:OK  
EASYCOOL/Water flow:OK  
EASYCOOL/Return press:OK  
EASYCOOL/Rtn press:xxx  
EASYCOOL/Motor temp:OK

This manual and design contains confidential proprietary information that is the property of Quantum Technology Corp. This manual is supplied to the customer under the express understanding that it is to be used by the Customer for the operational and service purpose only and that it is not to be transmitted or distributed to third parties without written consent.

This manual may only be used on the customer's premises.

Cold Head Run/YES-ON; NO-OFF

in the order listed below by scrolling the display.. If the DISPLAY button is pressed and not pressed again after 10 seconds, the display will return to EASYCOOL/ V3.3 (Stop Status), or EASYCOOL/RunTime : xxx (Operating Status).

Error conditions: If a system error that can cause an alarm or shutdown condition occurs, “OK “ sign as listed above will change from “OK” to “ERR”.

Any point that has not failed will continue to display OK .

If additional points fail before the operator resets the first error(s), the latest point to fail will change from “OK” to “ERR” and will be scrolled to the top of display. Due to this the operator will see the most recent fault displayed on the LCD and, by manually scrolling the display, can see other error conditions that lead up to the latest. If the operator does not press again in 3 seconds, the display will move the first error.

The “Ads time” displays the operating time of the absorber and remind the operator to replace the absorber in time. The records can be zero cleared.

Please contact the supplier for the absorber procurement and zero clearing.

## Trouble Shooting

An error condition will cause either a system alarm or a shutdown. The following table lists the alarm and the shutdown errors that are monitored. Overload trip of the Mains Power switch is not monitored or reported.

LCD Display Second Line	Type	Error	Indication
HHelium temp: ERR	Shutdown	High helium discharge temperature	Temperature > 93° C
Water temp: ERR	Alarm	High water supply temperature	Temperature > 35° C
Water flow: ERR	Alarm	Low water flow	Temperature > 46° C
Motor temp: ERR	Shutdown	High compressor motor winding temp (internal protector open)	Return Pressure > 9.7 bar
Phase Seq: ERR	Shutdown	Phase sequence or open fuse	Monitored by microprocessor
Return press: ERR	Shutdown	Loss of gas charge	Return pressure < 1.0 bar

If the compressor has been shut down by one of these interlocks, do not restart until the problem has been found and corrected. Refer to the Troubleshooting Guide to identify the problem. In the event of a shutdown error, the

This manual and design contains confidential proprietary information that is the property of Quantum Technology Corp. This manual is supplied to the customer under the express understanding that it is to be used by the Customer for the operational and service purpose only and that it is not to be transmitted or distributed to third parties without written consent.

This manual may only be used on the customer’s premises.

compressor motor and cold head valve motor are turned off. The microprocessor will annunciate the error condition via signals at the System Diagnostics Connector and via the LCD Display. Signals are available on the 25-pin connector for output to an external device. The Mains Power switch trips when steady-state current exceeds 1.2 x the front panel set point.

## Clearing Error Conditions

When an error is corrected, the message(s) can be cleared from the display and the system diagnostic connector by any of the following procedures:

1. Briefly contact the 5th and 24th pin of the diagnostic connector under remote control, or
2. Press the RESET under local control, or
3. Turn the Main Power switch to off, pause briefly, then turn back on

## Restarting after an Error Conditions

When the shutdown is caused by helium discharge high-temperature, the compressor will be able to restart only after it has cooled enough for the thermistor to read a temperature below the cut-off point. After waiting for the compressor to cool, clear the error message then push the ON button to restart. Should the compressor fail to start, allow more cooling time. Repeat the restart procedure. Check cooling water temperature and flow. Compare with Specifications.

If the shutdown is due to a motor high temperature, the motor winding high temperature relay will automatically reset in approximately 30 minutes. To restart the compressor, clear the error message then push the ON button. If the compressor fails to start, allow more cooling time. Repeat the restart procedure.

If the shutdown is due to a motor high current, reset it by turning the knob completely to OFF, then clockwise to ON. The compressor and the cold head should start automatically after a few seconds.

NOTE: The motor temperature switch is indirectly monitored by the pressure sensor.

When “Motor temp: ERR” is displayed, please check to see if the pressure sensor operates normally first.

## 7. Troubleshooting Guide

This manual and design contains confidential proprietary information that is the property of Quantum Technology Corp. This manual is supplied to the customer under the express understanding that it is to be used by the Customer for the operational and service purpose only and that it is not to be transmitted or distributed to third parties without written consent.

This manual may only be used on the customer's premises.

Problem	Possible Cause	Corrective Action
System shutdown, second LCD reads Helium Temp-ERR	Low oil level or blocked oil circulation.	Try five times to restart the compressor. If it does not start, consult the supplier.
	Supply water temperature is too high.	Scroll LCD display. If Water Temp-ERR is indicated, supply water temperature is too high. Provide 5° C to 25° C cooling water.
	Water flow rate is inadequate.	Scroll LCD display. If Water Flow-ERR is indicated, the water flow rate is too low. Set water flow rate at 6 to 9 L/min.
	Water flow is reversed.	Refer to Compressor Checkout for correct installation of the water lines.
	Faulty gas thermistor or PCB.	Contact the supplier.
When press the start button on the compressor, it does not start up, cold head motor starts. System shutdown 3 seconds later, LCD reads Motor temp: ERR	Helium flow reverse (Compressor supply port connects to cold head return port)	Check all the gas lines.
	Compressor motor windings high temperature switch opens. Compressor motor windings have overheated.	Scroll LCD display. If Water temp: ERR or Water flow: ERR is indicated, cooling water is inadequate. Refer to Specifications. Consult the supplier if the problem persists. Allow about 30 minutes for the windings to cool enough for the switch to reset.
	Reversed phase or loss of phase.	Check mains power.
	Fuse(s) opened or poor power quality.	If power checks indicate utilities are within specifications, check fuses.
	Pressure transmitter malfunction	Press DISPLAY, check the "Rtn press: xxx" to see if it is reasonable and if it is close to the readings on pressure gauge. If it is not in a reasonable range, contact the supplier service.

This manual and design contains confidential proprietary information and is the property of Quantum Technology Corp. This manual is supplied to the customer under the express understanding that it is to be used by the Customer for the operational and service purpose only and that it is not to be transmitted or distributed to third parties without written consent.

This manual may only be used on the customer's premises.



System shutdown LCD reads Phase seq: ERR	Fuse(s) opened or poor power quality	If power checks indicate utilities are within specifications, check fuses.
System shutdown LCD Return press: ERR	Compressor has lost helium charge	Refer to Charging or Venting, Gas Clean-up and Leak Check in the Manual.
	Pressure transmitter malfunction	Contact the supplier.
Compressor and cold head motor do not start when the start switch on the compressor is pushed.	No electrical power.	Check that the power source is on and connected.
	Wrong voltage	Refer to the Power Supply Specification in the system manual.
	Main power phase sequence is wrong.	Interchange any two- (2) incoming power leads (except ground).
	Defective component in the power circuit.	Refer to Compressor Motor troubleshooting in this section.
	Tripped motor circuit protector on the front panel.	Reset the protector by turning the knob to OFF, then turn the knob clockwise to ON. Consult the supplier if the problem persists.
Compressor starts but shuts down later	Insufficient coolant for the compressor	Check the coolant flow and temperature. Refer to Specifications.
System starts but gas pressure is abnormally high or low.	Wrong equalization pressure.	Refer to Specifications and the section on Charging or Venting.
	Gas line couplings are not fully engaged.	Be sure that all gas couplings are fully engaged and torqued.
	Gas lines are connected wrong.	Reconnect. See the Installation section.
Cold head motor does not start when the compressor starts.	Cold head cable is not connected.	Stop the compressor. Connect the cable. Check connections at the cold head and at the compressor.
	Open circuit in the cold head cable.	Disconnect the cable. Check each conductor for continuity. Replace the cable if necessary.
	Fuse to protect the cold head motor is blown.	Contact the supplier to replace the fuse inside the electrical enclosure.

This manual and design contains confidential proprietary information that is the property of Quantum Technology Corp. This manual is supplied to the customer under the express understanding that it is to be used by the Customer for the operational and service purpose only and that it is not to be transmitted or distributed to third parties without written consent.

This manual may only be used on the customer's premises.

Cold head motor hums but does not start.	Open circuit in the cold head cable.	Disconnect the cable. Check each conductor for continuity. Replace the cable if necessary.
	Bad quality of input power	Check input power, compare with specifications.
	Fuse to protect the cold head motor is blown.	Contact the supplier to replace the fuse inside the electrical enclosure.
Cold head motor runs, but there is no cooldown.	Gas line couplings are not fully engaged.	Be sure that all gas couplings are fully engaged and torqued.
	Gas lines are connected wrong.	Reconnect. See the Installation section.
Intermittent operation.	Compressor is cycling on and off.	Check input power, coolant flow and temperature. Compare with Specifications.
Loss of refrigeration capacity.	Compressor malfunction.	Check input power, coolant flow and temperature, and equalization pressure. Compare with Specifications.
Compressor shuts down, LCD display is blank	Fuse to protect the cold head motor is blown.	Contact the supplier to replace the fuse inside the electrical enclosure.
	Malfunctioning control boards.	Contact the Supplier Service Center.
Compressor is unresponsive to remote or remote status signals do not match actual status (DB-25 diagnostic interface)	DB-25 pins are not connected to the peripheral configuration as specifications require.	Turn off the power. Connect the peripheral configuration based on the DB25 interface definition in specifications.
	PCB board malfunction	Contact the Supplier Service Center.

This manual and design contain confidential proprietary information and is the property of Quantum Technology Corp. This manual is supplied to the customer under the express understanding that it is to be used by the Customer for the operational and service purpose only and that it is not to be transmitted or distributed to third parties without written consent.

This manual may only be used on the customer's premises.

## 8. APPENDIX

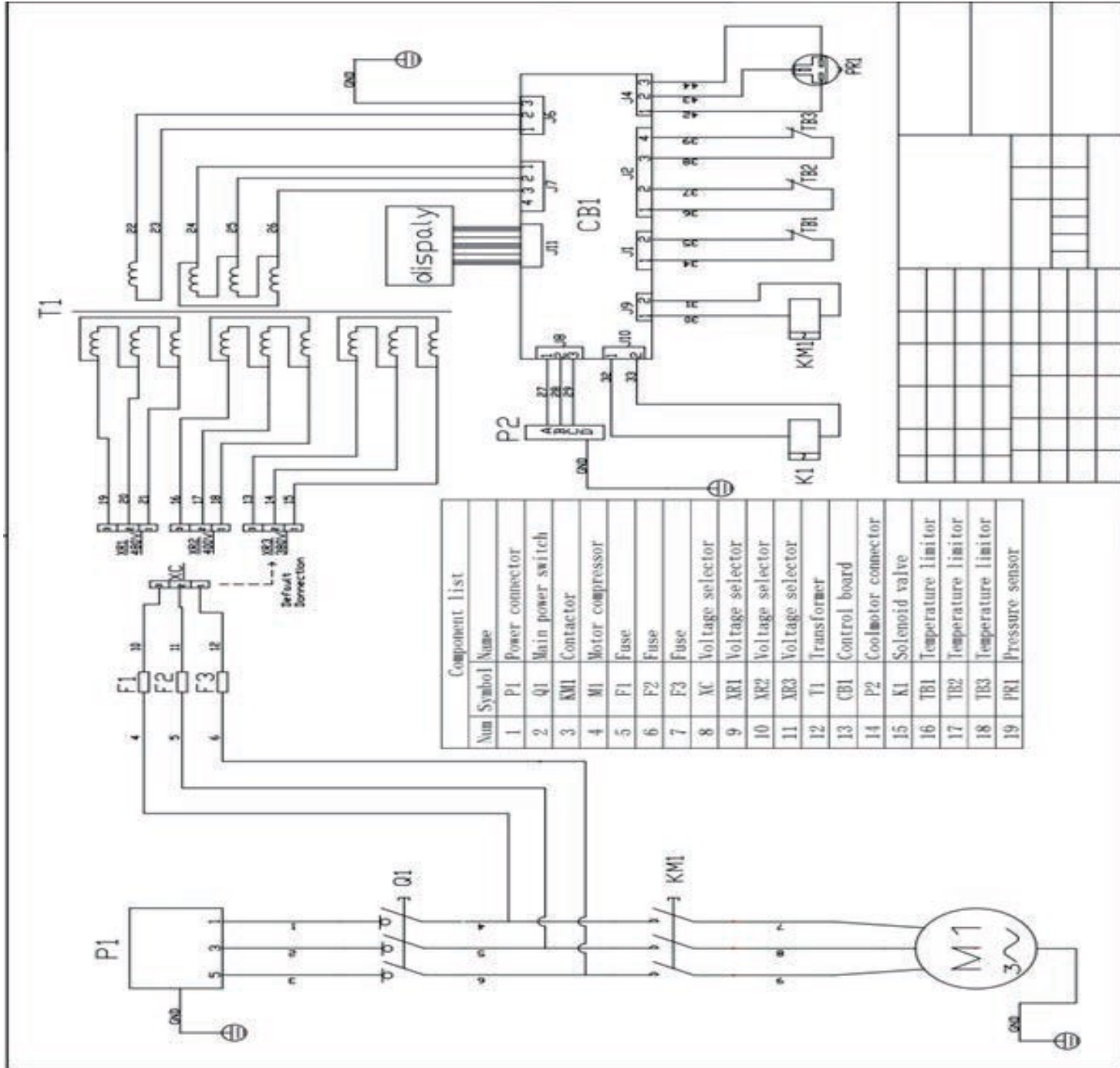

Appendix 1: QCLHEW compressor Wiring Diagram

This manual and design contains confidential proprietary information that is the property of Quantum Technology Corp. This manual is supplied to the customer under the express understanding that it is to be used by the Customer for the operational and service purpose only and that it is not to be transmitted or distributed to third parties without written consent.

This manual may only be used on the customer's premises.

PIN	Function	Description
4	Pause cold head motor	The cold head motor will turn off while PIN7 is connected to PIN12 if Remote Control is ON and System is ON.
5	Reset system errors	System errors will be reset while PIN5 is connected to PIN12.
6	Turn ON/OFF system	The compressor and cold head will turn on when PIN6 is connected to PIN12.
7	Turn ON/OFF remote control	When PIN7 is connected to PIN12, system can operate by remote control, cannot operate by local control.
12、 8	Ground(0V)	
13、 5	DC24V	
1	Absorber time error	When the absorber time > 27000 hours, PIN1 is 0V. When the absorber time < 27000 hours, PIN1 is HIGH impedance.
10	Output the value of compressor return pressure	This pin will carry 0.5 - 4.5VDC signal relative to pin 24. The pressure calculation formula: Return pressure (absolute pressure, Bar) = (V - 0.5) * 8.62.
14	Run status	When the compressor and cold head stop, this pin HIGH impedance. When the compressor and cold head run, this pin is 0V.
15	Motor winding temperature error	When the motor winding temperature error does not happen, this pin is 0V. When the compressor is run, this pin is HIGH impedance.
16	Solenoid valve status	When the internal bypass solenoid valve is opened, this pin is 0V. When the internal bypass solenoid valve is closed, this pin is HIGH impedance.
17	Phase sequence error	When the phase sequence error or fuse error does not happen, this pin is HIGH impedance. When the phase sequence error or fuse error happens, this pin is 0V.
18	Water temperature error	When the water temperature error does not happen, this pin is HIGH impedance. When the water temperature error happens, this pin is 0V.
19	Water flow error	When the water flow error does not happen, this pin is HIGH impedance. When the water flow error happens, this pin is 0V.
21	Helium temperature error	When the helium temperature error does not happen, this pin is HIGH impedance. When the helium temperature error happens, this pin is 0V.
23	Return pressure error 0VDC analog signal	When the return pressure error does not happen, this pin is HIGH impedance. When the return pressure error happens, this pin is 0V.

This manual and design contains confidential proprietary information that is the property of Quantum Technology Corp. This manual is supplied to the customer under the express understanding that it is to be used by the Customer for the operational and service purpose only and that it is not to be transmitted or distributed to third parties without written consent.

This manual may only be used on the customer's premises.

Appendix 2: DB25 Pin Functions

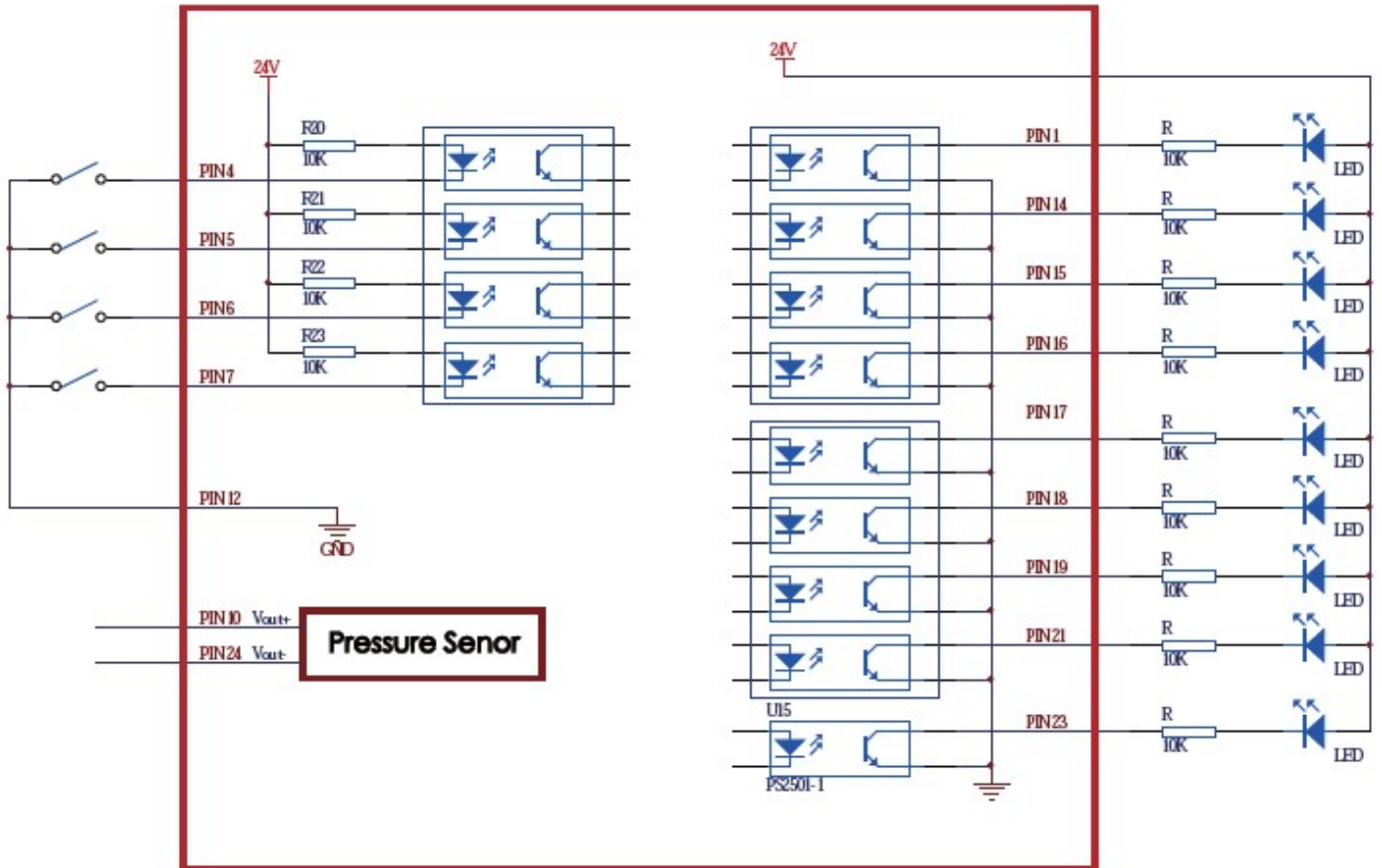

Appendix 3: Diagram

This manual and design contains confidential proprietary information that is the property of Quantum Technology Corp. This manual is supplied to the customer under the express understanding that it is to be used by the Customer for the operational and service purpose only and that it is not to be transmitted or distributed to third parties without written consent.

This manual may only be used on the customer's premises.