

Dilution Factor and Systematic Error

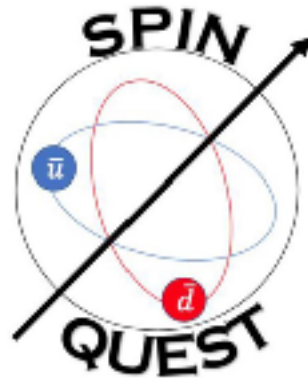

Anchit Arora

Prof. Dustin Keller

University of Virginia

Fermilab



Outline:

- SpinQuest introduction
- Polarized target & dilution factor
- Cross-section generator
- Sources of error
- Dynamic dilution factor error
- Summary

SpinQuest Introduction

- Find the contribution of the constituent partons to the nucleon spin.
- Siverson function describes the correlation between the momentum direction of the struck quark and the spin of its parent nucleon
- If sea-quark Siverson asymmetry is non-zero, then sea quarks have non-zero OAM.
- In order to measure the Siverson function we need a polarized target.

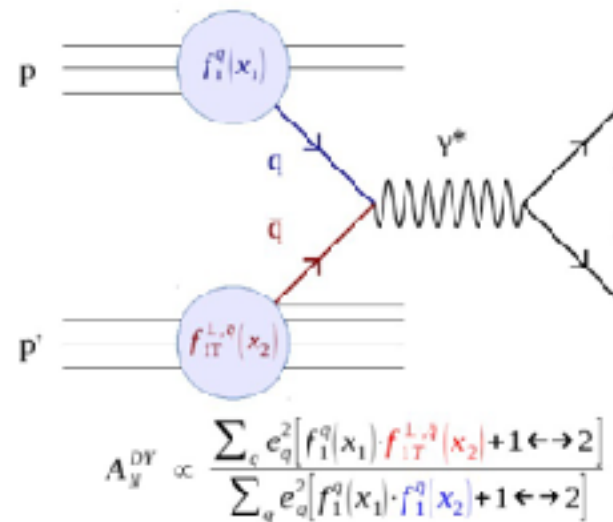

Drell-Yan process and the Siverson Assymetry equation

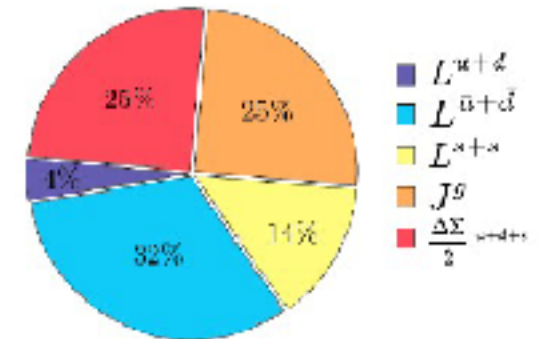

Proton spin components
Lattice QCD: K.-F. Liu et al arXiv:1203.6388

SpinQuest Introduction

- Measure the Sivers asymmetry for the \bar{u} and \bar{d} sea quarks using the Drell-Yan process.
- Error in Dilution factor directly affects the figure of merit of the experiment.

$$A_T = \frac{2}{f|S_T|} \int d\phi_S d\phi \frac{dN(x_B, x_T, \phi, \phi_S)}{d\phi_S d\phi} \sin(\phi_S) N(x_b, x_T)$$

Sivers Assymetry equation

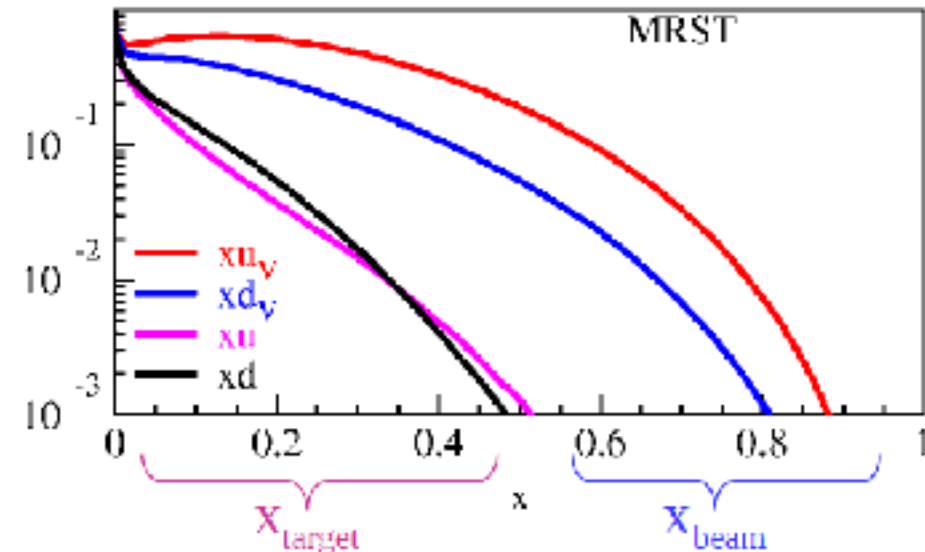

Kinematics dependence MRST x target Xbeam

E-1039 Experimental Setup

A Drell-Yan dimuon experiment

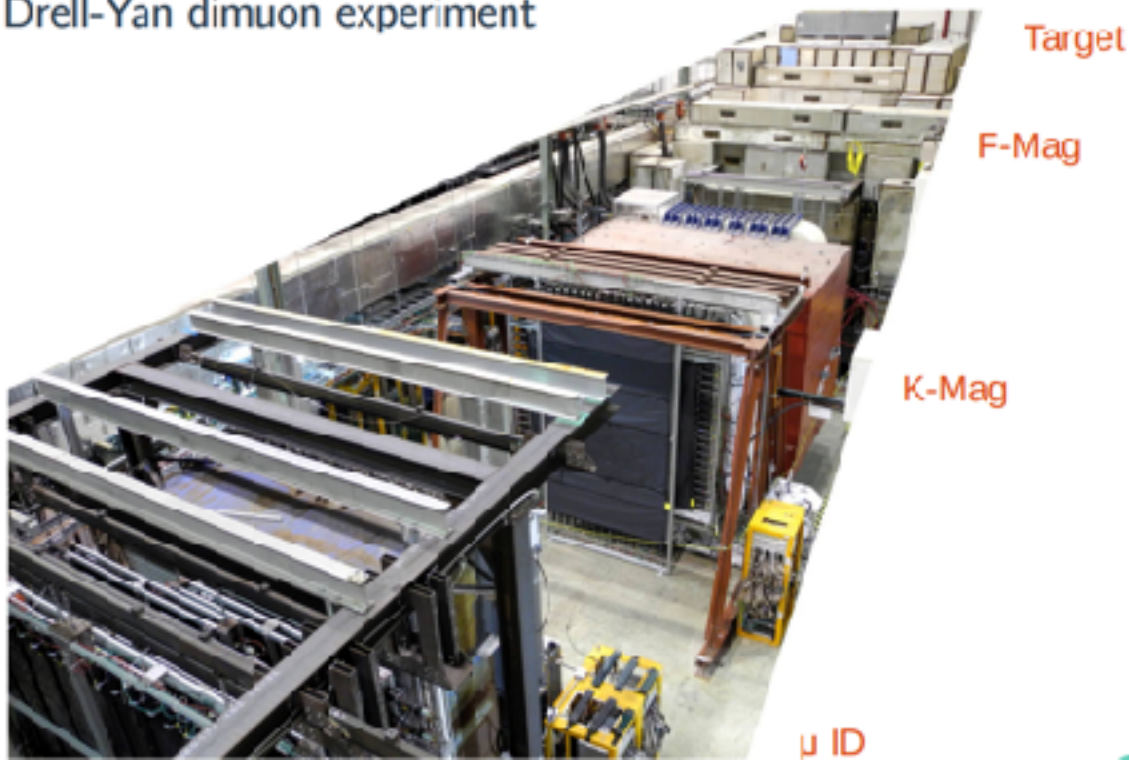

Detector system assembly

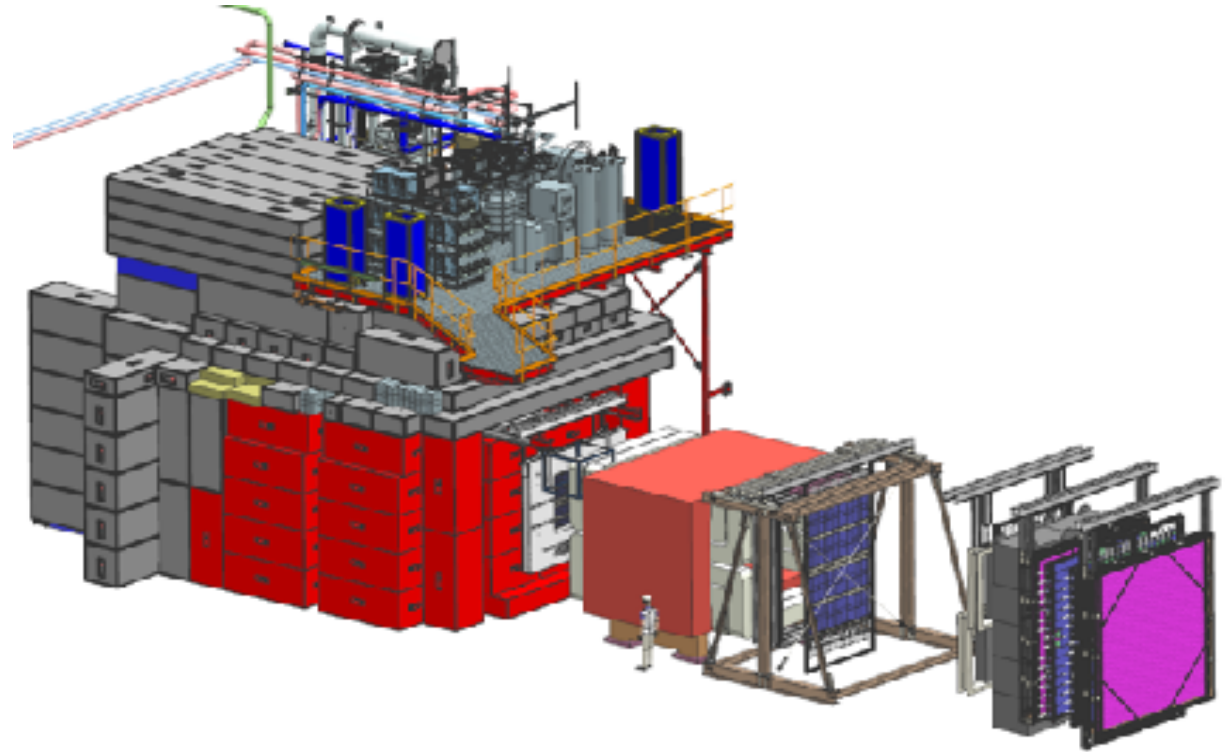

- 120 GeV proton beam from the main injector
- 4s Beam spill every 60s
- 19 ns RF $\sim 10^8$ K proton per RF bucket
- $\sim 4 \times 10^{12}$ proton on target (POT) per spill
- Project proposed to run for 2 years

Target

- The target consists of an 8cm long PTFE target cells containing ammonia beads immersed in liquid Helium.
- The cooling power of the He-evaporation refrigerator is 1.4 W at 1 K assuming a flow rate of 20 SLPM (normal operation).
- Our target system will contain polarized NH_3 (proton target) and polarized ND_3 (neutron target)
- $dB/B < 10^{-4}$ at 5T over 8 cm
- This is a high cooling power DNP (Dynamic Nuclear Polarization) target achieved with the help of high pumping rate and the refrigerator. Pumping rate $\sim 16800 \text{ m}^3/\text{hr}$.

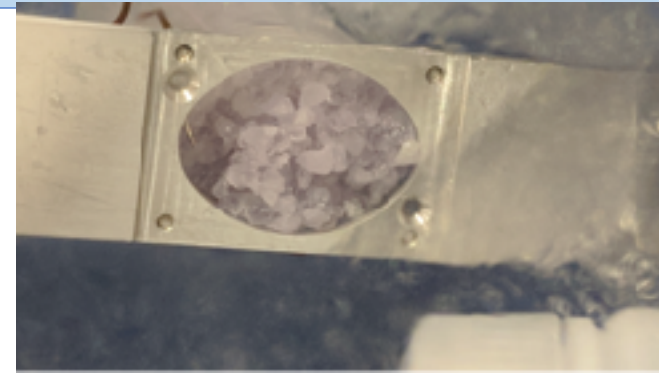

Target cup filled with material

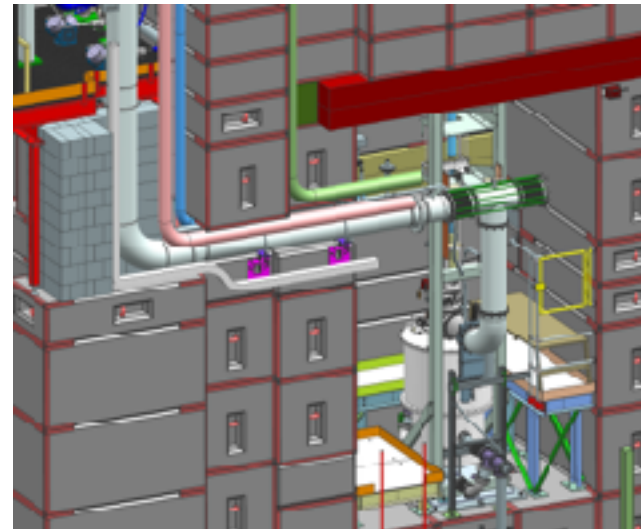

Target in the alcove

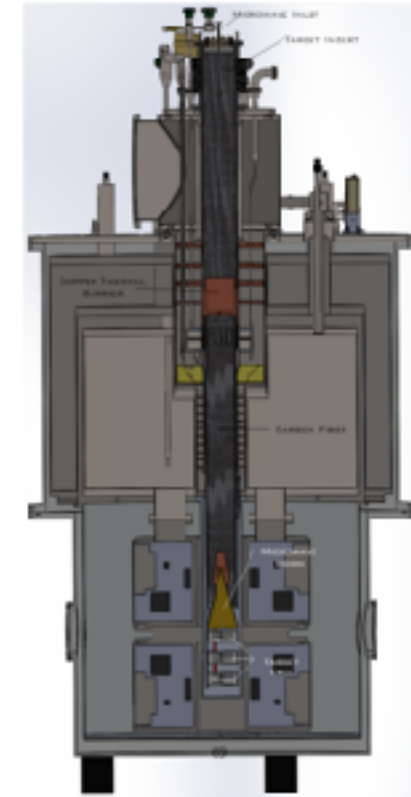

Target with the insert

NH₃ & ND₃ Targets

Running time for a chosen accuracy $\propto 1/P_T^2 \cdot \rho \cdot f^2 \cdot \kappa$

κ = packing fraction
 ρ = density
 f = dilution factor

¹⁴NH₃

- Optimized proton target
- Moderate f
- High resistance to radiation damage
- Polarization calibration error ~3%

¹⁴ND₃

- Optimized neutron target ($P_n = 0.91P_D$)
- Larger f
- High resistance to radiation damage
- Polarization calibration error ~5%

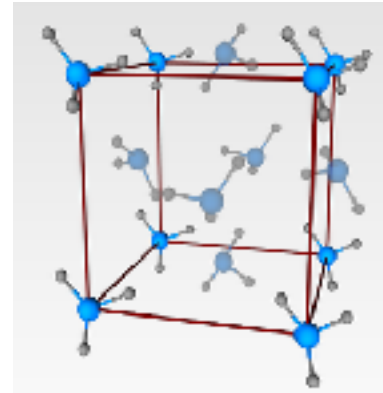

Cubic structure of Ammonia

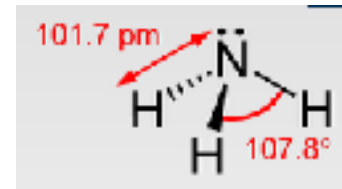

Ammonia Molecular structure

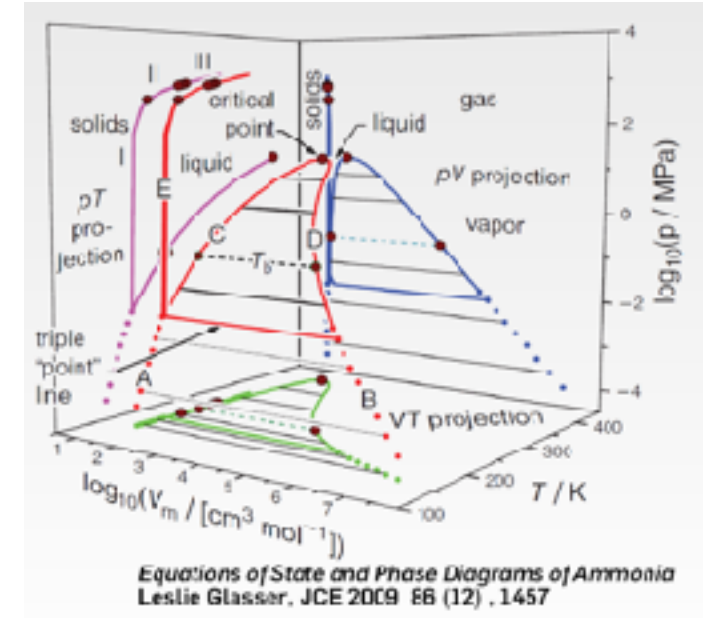

Spin-1 ¹⁴N background, but computable

	P_T		f	κ	FOM
ND ₃	0.45	1.007	0.3	0.6	0.0110
NH ₃	0.90	0.853	0.176	0.6	0.0128

Dynamic Nuclear Polarization

- Target polarization process
- Transfer of spin polarization from electrons to nuclei
- Electrons 1K 5T ~ 98%
 - Brute force method Protons at 1K 5T ~ 0.5%
 - DNP Proton Polarization at 1K 5T ~ 96%
- Dope target material with paramagnetic centers
- Using microwave to transfer the polarization to nuclei.
- Microwave frequency: 140 GHz
- Thermal Equilibrium polarization:

$$P = \frac{e^{\frac{\mu B}{kT}} - e^{-\frac{\mu B}{kT}}}{e^{\frac{\mu B}{kT}} + e^{-\frac{\mu B}{kT}}} = \tanh\left(\frac{\mu B}{kT}\right)$$

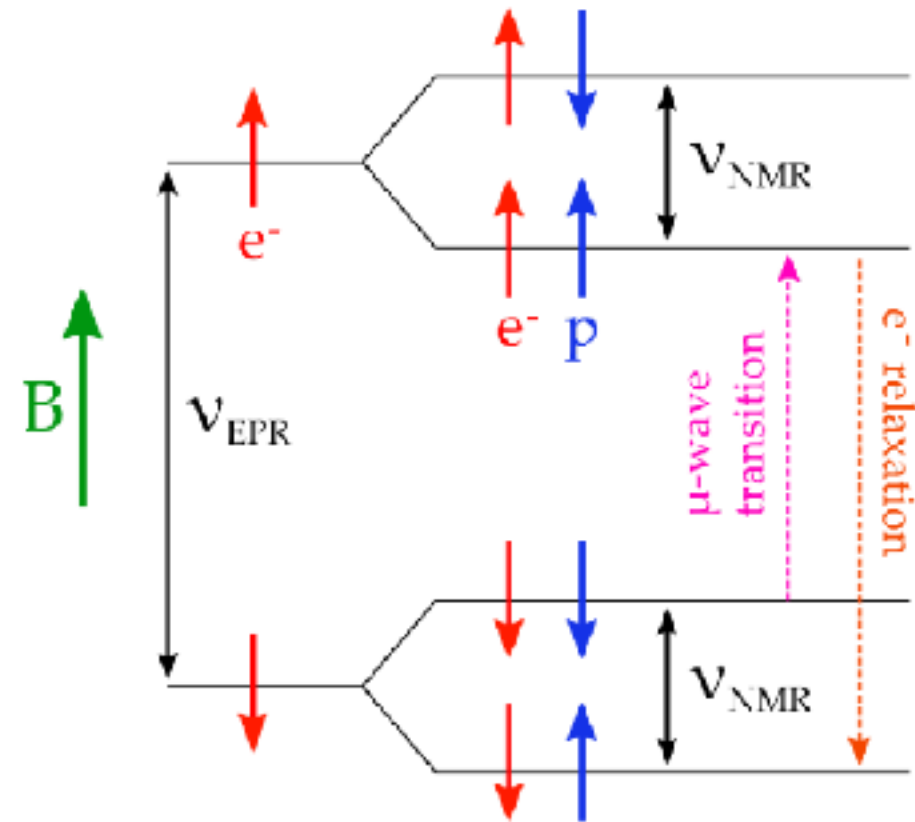

Projections of Error

Beam (~2.5%):

- Relative Luminosity (~1%)
- Drifts (<2%)
- Scraping (~1%)

Analysis sources (~3.5%):

- Tracking Efficiency (~1.5%)
- Trigger and Geometrical Acceptance (<2%)
- Mixed background (~3%)
- Shape of DY (~1%)

Target (~6-7%)

- **Dilution factor (~3%)**
- Polarization inhomogeneity (~2%)
- Packing fraction (~2%)
- Density of target (ammonia) (~1%)
- TE calibration (P~2.5% D~4.5%)
- Uneven radiation damage (~3%)
- Beam/target misalignment (~0.5%)

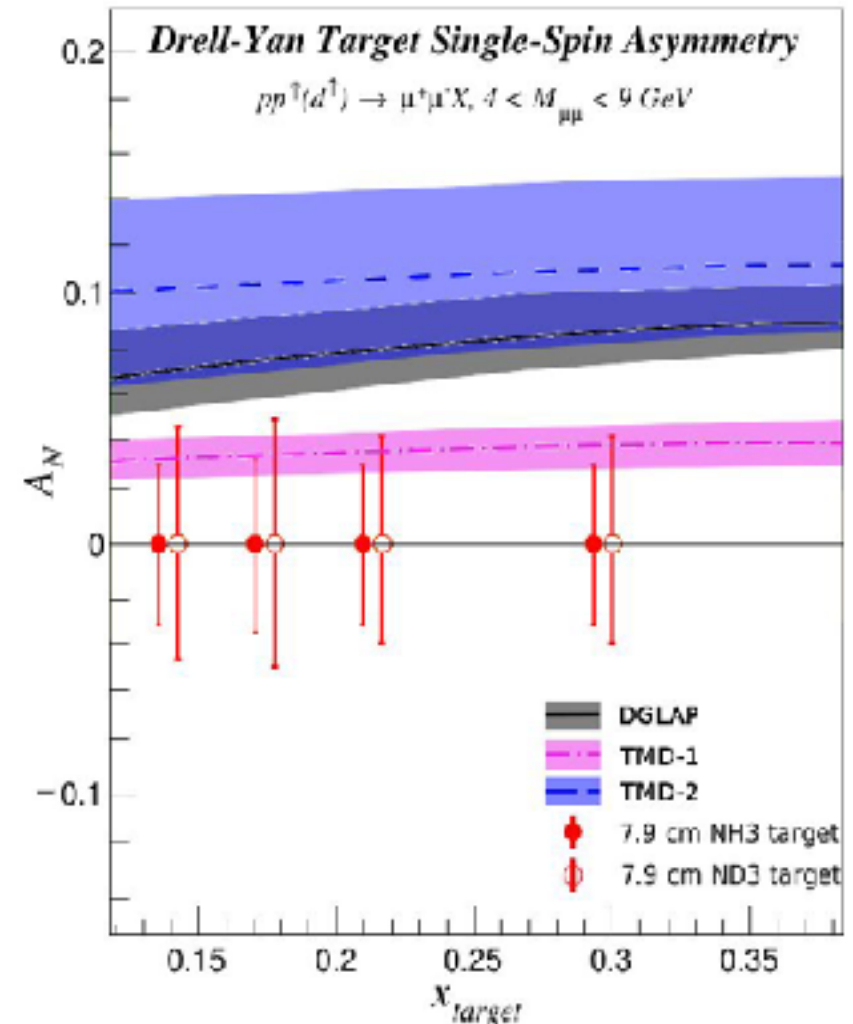

Dilution Factor

- **Static dilution factor** is defined as the ratio of number of polarizable nucleons to total no. of nucleons in the target. **Defines the figure of merit of the target material.**
- **Kinematic dilution factor** is defined as the ratio of cross section of polarizable nucleons to the cross section of all the nucleons in the target. **Defines the figure of merit of the target material.**
- The denominator of the dilution factor can be written in terms of the relative volume ratio of ND₃ to LHe in the target cell, the packing fraction pf .
- For the case of a cylindrical target cell oriented along the magnetic field, the packing fraction is exactly equivalent to the percentage of the cell length filled with NH₃ or ND₃. The dilution factor for NH₃ is 0.176 and for ND₃ is 0.3.
- The uncertainty in these factors from irreducible background is typically 2-3%.

$$f_{NH3} = \frac{N_H}{N_H + NN_{14}} = \frac{3}{3 + 14} = \frac{3}{17}$$

Static Dilution Factor(Hydrogen)

$$f(x) = \frac{N_H \sigma_{pp\uparrow}^{DY}(x)}{N_H \sigma_{pp\uparrow}^{DY}(x) + N_{N14} \sigma_{pp\uparrow}^{DY}(x) + N_{He} \sigma_{p p\uparrow}^{DY}(x) + N_{Al} \sigma_{pp\uparrow}^{DY}(x) + \dots}$$

Dynamic Dilution Factor(Hydrogen)

$$f_{ND3} = \frac{N_D}{N_D + NN_{14}} = \frac{6}{3 + 17} = \frac{3}{10}$$

Static Dilution Factor(Deuteron)

$$f(x) = \frac{N_D \sigma_{pD\uparrow}^{DY}(x)}{N_H \sigma_{pD\uparrow}^{DY}(x) + NN_{14} \sigma_{pp\uparrow}^{DY}(x) + N_{He} \sigma_{p p\uparrow}^{DY}(x) + N_{Al} \sigma_{pp\uparrow}^{DY}(x) + \dots}$$

Dynamic Dilution Factor(Deuteron)

Contribution (Non Target)

Using the SpinQuest simulation for a particular event rate we find the percentage of dimuon events that are detected, broken down into contributions of materials:

- Aluminum(Nose piece)
- Target cell(PTFE)
- Gold + Copper(microwave horn)
- NMR coils
- Aluminum Foil on the cups
- Aluminum Ladder
- Liquid Helium
- Target material

Notes: $\sim 4 \times 10^{12}$ protons per spill. What fraction produces dimuon events that we can detect. What fraction are from above listed materials.

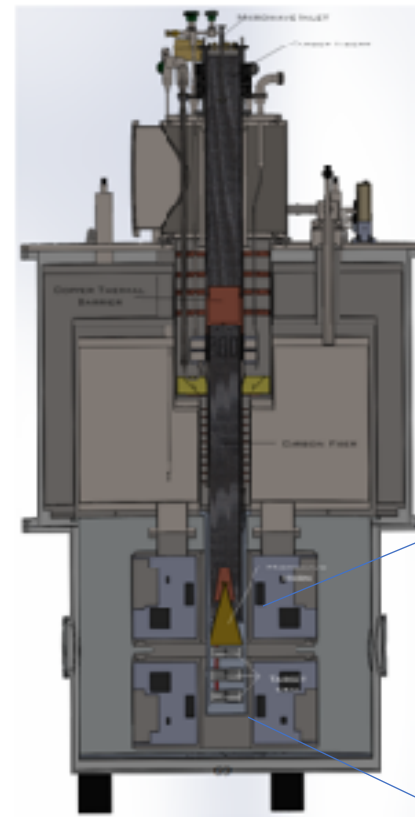

Cross-section of the target

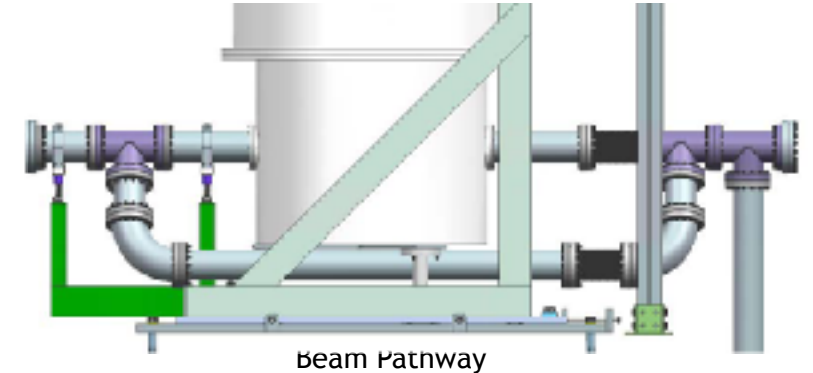

Beam Pathway



Target cells with the microwave horn

MCFM (Monte Carlo for FeMtobarn)

- MCFM: parton-level Monte Carlo program, gives NLO predictions for a range of processes at hadron colliders.
- Developed at Fermilab by:
 - John M. Campbell** (johnmc@fnal.gov)
 - R. Keith Ellis** (ellis@fnal.gov)
 - Walter Giele** (giele@fnal.gov)
 - Tobias Neumann** (tneumann@fnal.gov)
 - Ciaran Williams** (ciaranwi@buffalo.edu)
- Drell-Yan cross-section generator (at 15GeV)
- Collection of modern parton distribution functions that are included with MCFM.
- Built event generator based on MCFM distributions

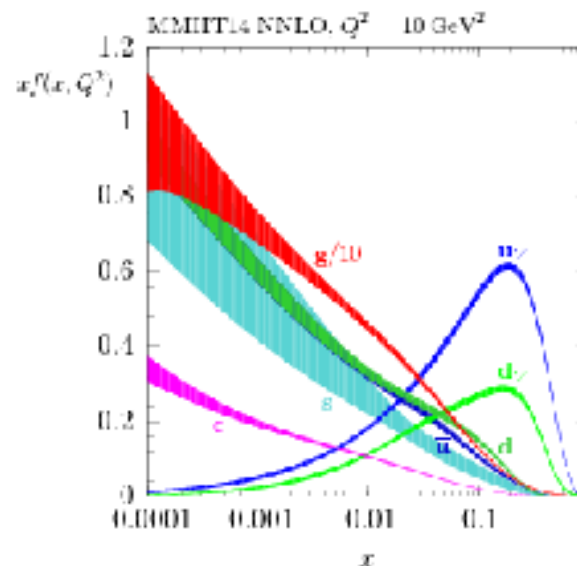

pdlabel	$\alpha_S(M_Z)$	order	reference
mstw8lo	0.1394	1	[41]
mstw8n1	0.1202	2	[41]
mstw8nn	0.1171	3	[41]
MMHT_lo	0.135	1	[35]
MMHT_n1	0.120	2	[35]
MMHT_nn	0.118	3	[35]
CT10.00	0.118	2	[38]
CT14_LL	0.130	1	[24]
CT14_NL	0.118	2	[24]
CT14_NN	0.118	3	[24]
CT14qed	0.118	2	[53]
NN2.3NL	0.118	2	[5]
NN2.3NN	0.118	3	[5]
NN3.0LO	0.118	1	[4]
NN3.0NL	0.118	2	[4]
NN3.0NN	0.118	3	[4]

List of PDFs available with MCFM

Test Of MCFM

Medium energies
(Comparison with experiments E866 and E772) =38.7 GeV

Effects:

1. **EMC effect:** DIS cross-section from the nucleons in nucleus is different from same number of free nucleons(E772)
2. Flavor Asymmetry (NuSea/E866)

E1039 $\sqrt{s} = 15\text{GeV}$

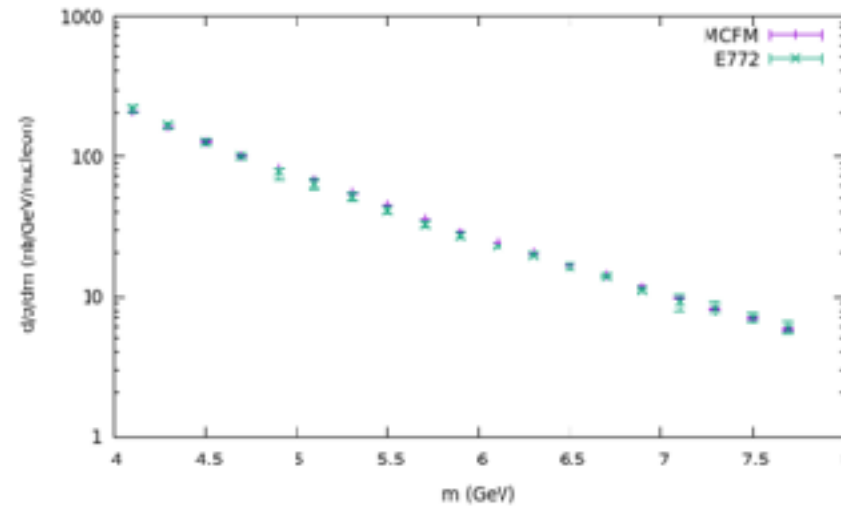

Comparison of E772 with MCFM

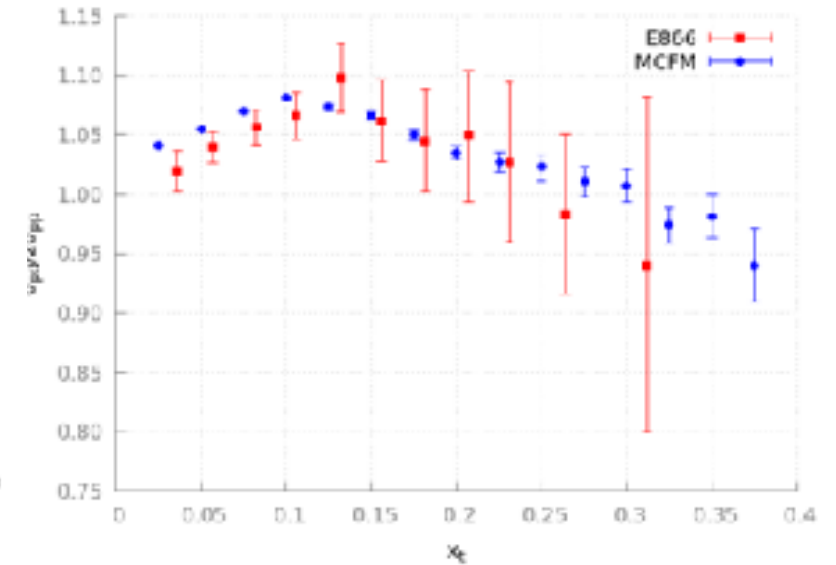

Comparison of E866 with MCFM

MCFM Generated Cross-Sections (E1039)

- MCFM generated twenty million events (fifty iterations of four-hundred thousand events each) by sampling the CT14 PDFs.
- Cross-section calculated using MCFM for Nitrogen and Hydrogen at:
 $\sqrt{s} = 15\text{GeV}$

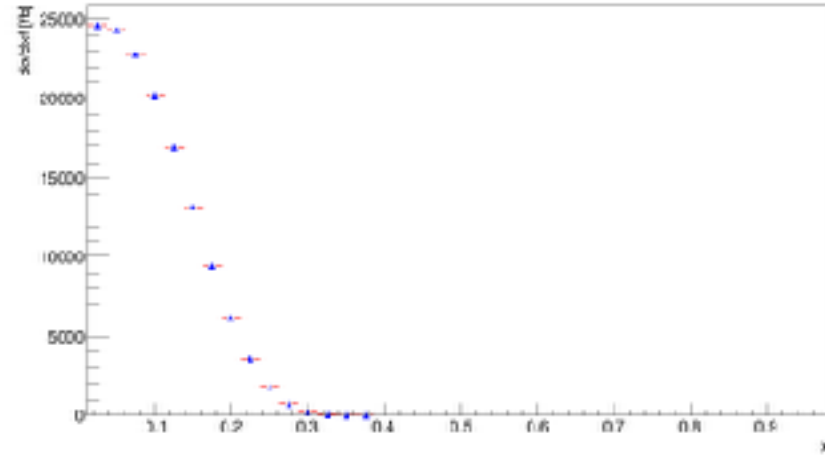

Helium cross-section(E1039)

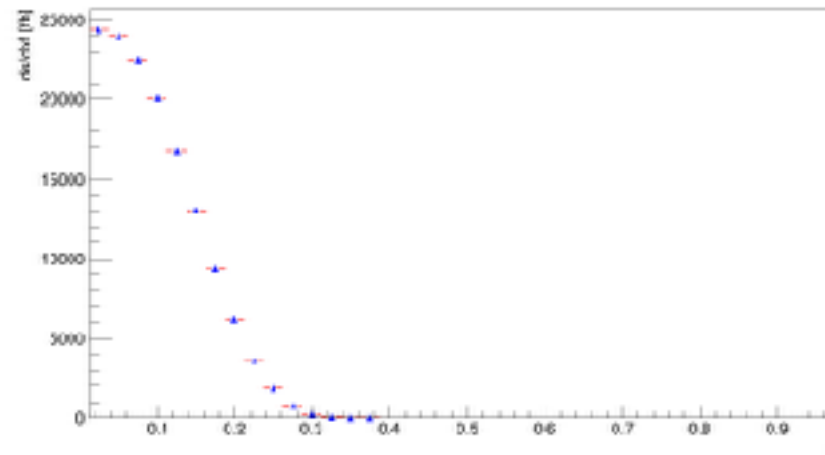

Nitrogen cross-section(E1039)

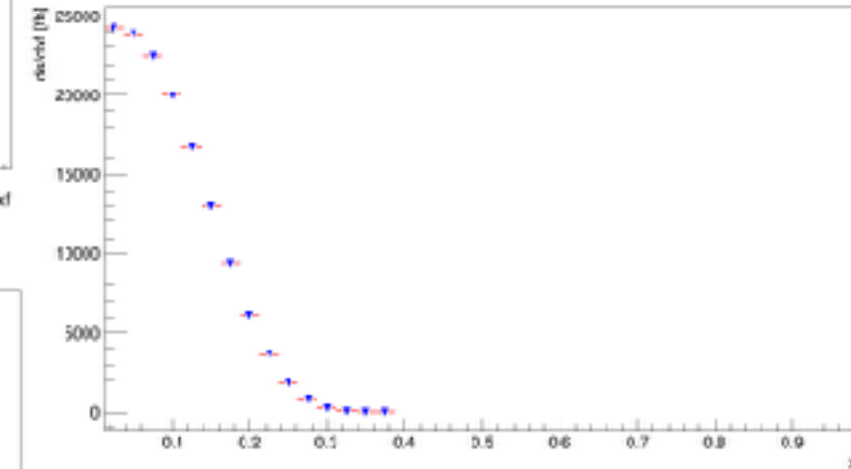

Aluminum cross-section(E1039)

Target Composition Dependence

- Dilution factor also depends on the materials in the target.
- Using helium differential cross-sections, we found the dilution factor for different ratios of ammonia to helium.
- By doing so, we were able to estimate effect of uncertainty in target composition.
- The cups are made up of polychlorotrifluoroethylene.

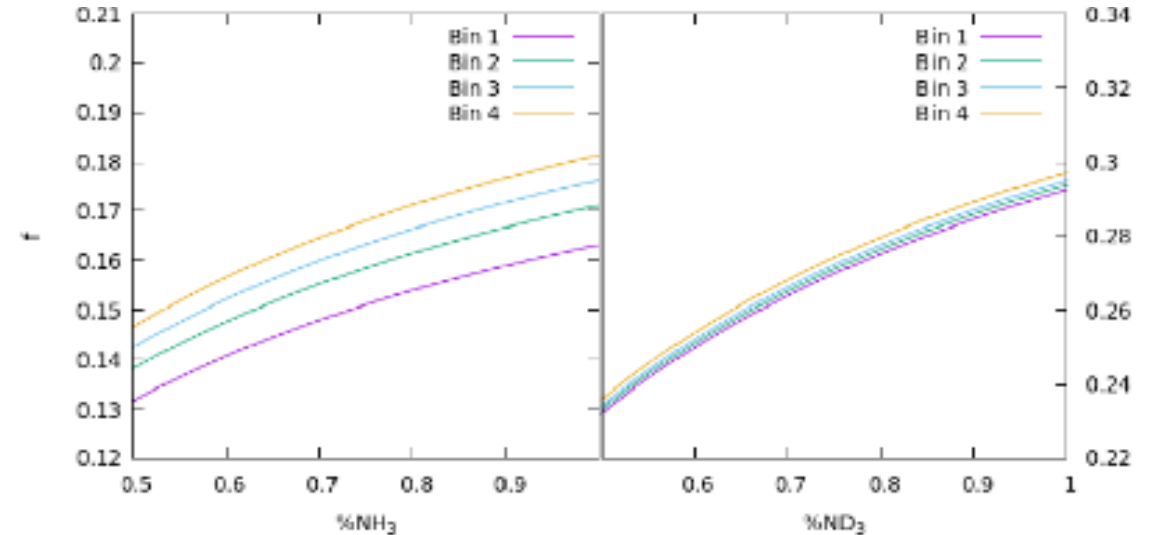

Dilution factor for mixtures of ammonia and Helium for different ratios of ammonia

Relative dilution factor calculation can help with reducing the error due to target composition.

Bin	X_T	Bin	\bar{d}/\bar{u} (%)	EMC (%)	NH ₃ Error (%)
1	0.10-0.16	0.10-0.16	0.5	0.5	0.7
2	0.16-0.2	0.16-0.20	1.0	0.5	1.1
3	0.20-0.24	0.20-0.24	1.5	0.5	1.6
4	0.24-0.60	0.24-0.6	2.0	1.5	2.5

Summary

- Many systematic error components to the target that need to be managed.
- One of the critical ones is the dilution factor.
- Explained using MCFM to create an event generated to be used in monte-carlo simulations to be used in the study of various target materials
- Able to estimate the dynamic dilution factor as a function of Drell-Yan kinematics and the corresponding systematic error in each bin.
- Moving forward:
 - Do a thorough analysis of acceptance of dimuons from various materials.
 - Looking in detail in other target systematics