



Magnet Rack & Cryo Rack

ORC Update – 3/4/2021

Outline

- Magnet Rack
- Cryo-Rack

Magnet Rack: Remaining issue

Cable list: Most cable has been specified. But the **ITM10 & Shim-PS** cables have not been specified since they are covered by the shielding. See the following couple of slides for the new setup dan cable list

Possible solution:

1. See/guess the type of the shielding
2. Open the connector to see how many gauge wire inside
3. Measure the diameter (AWG size)

Terminal issue from Rick: The 208V 3 phase distribution in Figure 3 does not have sufficient detail. Looking at the terminal block where the distribution occurs, the diagram is wrong (not enough wires on the output side going to the power strips). Also, I think this construction will not pass because the 208V looks to be a 10AWG wire and the wires going into the power strips look to be 18 AWG (this is asking to start a fire without fusing).

Solution: Waqar, could you please draw a new terminal-block diagram? Thank you

Next step: Could you please show the new terminal-block diagram (after Waqar finish the drawing) along with the cable list and schematics shown in the following slides to Rick?

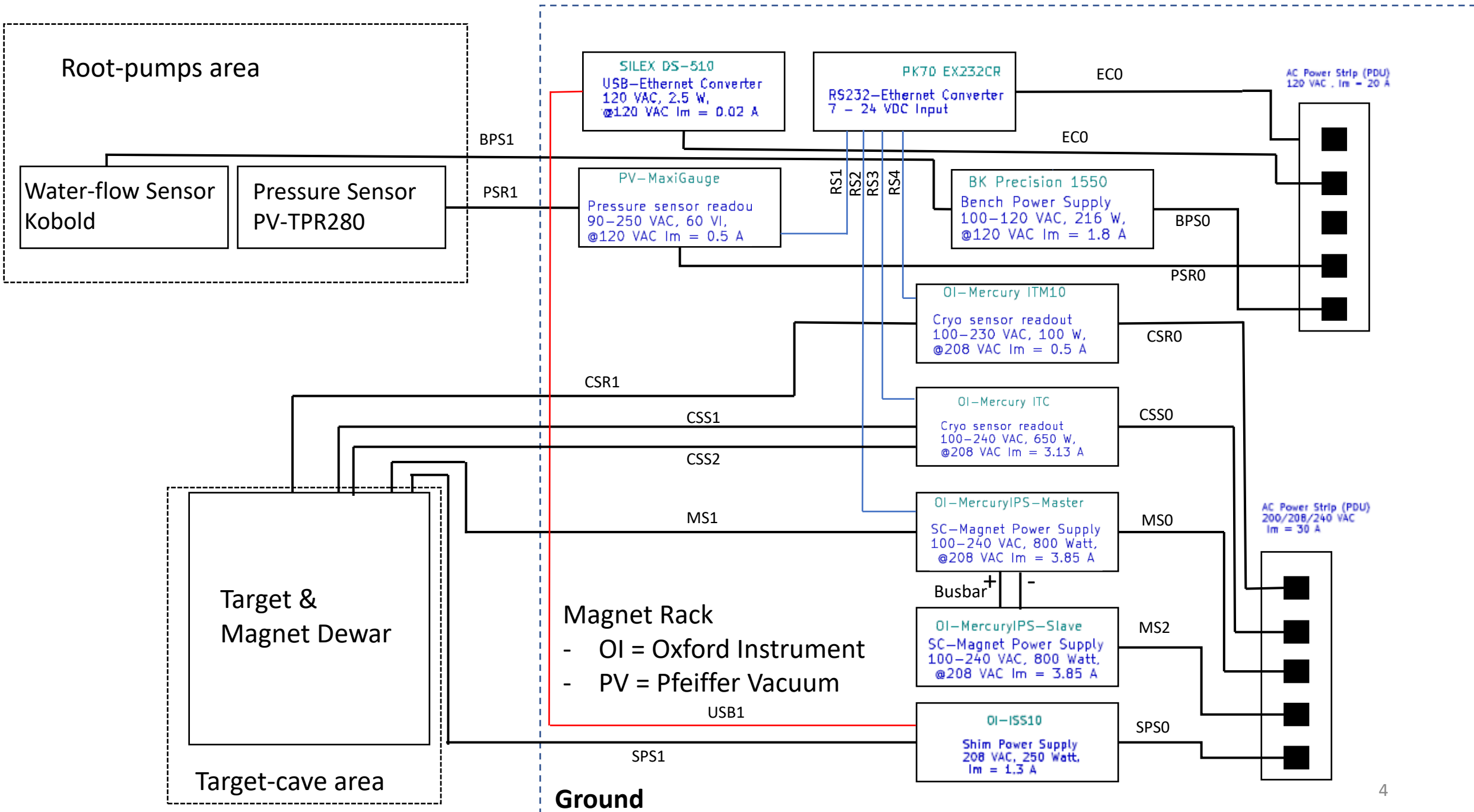

Root-pumps area

Water-flow Sensor
Kobold

Pressure Sensor
PV-TPR280

Target &
Magnet Dewar

Target-cave area

Magnet Rack
 - OI = Oxford Instrument
 - PV = Pfeiffer Vacuum

Ground

SILEX DS-510
 USB-Ethernet Converter
 120 VAC, 2.5 W,
 @120 VAC Im = 0.02 A

PK70 EX232CR
 RS232-Ethernet Converter
 7 - 24 VDC Input

PV-MaxiGauge
 Pressure sensor readout
 90-250 VAC, 60 VI,
 @120 VAC Im = 0.5 A

BK Precision 1550
 Bench Power Supply
 100-120 VAC, 216 W,
 @120 VAC Im = 1.8 A

OI-Mercury ITM10
 Cryo sensor readout
 100-230 VAC, 100 W,
 @208 VAC Im = 0.5 A

OI-Mercury ITC
 Cryo sensor readout
 100-240 VAC, 650 W,
 @208 VAC Im = 3.13 A

OI-Mercury IPS-Master
 SC-Magnet Power Supply
 100-240 VAC, 800 Watt,
 @208 VAC Im = 3.85 A

OI-Mercury IPS-Slave
 SC-Magnet Power Supply
 100-240 VAC, 800 watt,
 @208 VAC Im = 3.85 A

OI-ISS10
 Shim Power Supply
 208 VAC, 250 Watt,
 Im = 1.3 A

AC Power Strip (PDU)
 120 VAC, Im = 20 A

AC Power Strip (PDU)
 200/208/240 VAC
 Im = 30 A

Cable	Description
EC0	AC power cord
EC0	AC power cord
PSR0	AC power cord
PSR1	Factory made sensor cable (Pfeiffer Vacuum, catalog number PT448252- T)
BPS0	AC power cord
BPS1	AWG 18-gauge wire
SPS0	AC power cord
CSR0	AC power cord
CSS0	AC power cord
MS0	AC power cord
MS1	Factory-made power cable (Eland cable: BS 638:PART 4 H.O.F.R 85 DEG.C 25 MM2 ELAND)
MS2	AC power cord
SPS1	?
CSR1	?
CSS1	Helium probe sensor cable (Oxford Inst. : 7-2-4C P46339 CNC6700 HE) with extension of AWM 2464 cable
CSS2	Nitrogen probe sensor cable (Oxford Inst. : 7-2-4C IEC60332.1 CNC6600 N2) with extension of AWM 2464 cable

Cable	Description
USB1	USB cable
RS1	RS232 cable
RS2	RS232 cable
RS3	RS232 cable
RS4	RS232 cable

Cryo Rack: Power distribution

In the following slides, I make summaries of:

1. Power consumption, maximum current, 120/240 VAC requirement, Neutral requirement for each subsystem that will sit on the Cryo rack: Cryo control, lifter control, Microwave system, slow control & other system.
2. Total power consumption and current
3. Power consumption & current for devices that require 120 VAC, single-phase, and require Neutral
4. Power consumption & current for devices that require 240 VAC, single-phase, and NO neutral
5. Power consumption & current for devices that could work both with 120 & 240 VAC, single-phase, and require Neutral

Next step: Waqar, based on these information (also following slides), could you please draw the terminal-block diagram like the diagram for the magnet rack below

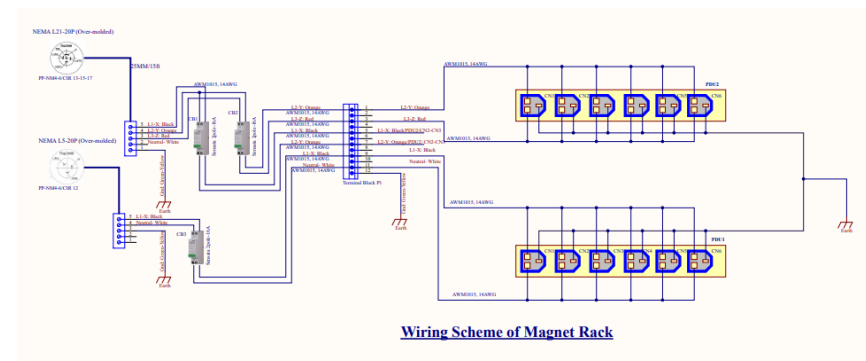

Cryo Control	Max Power (Watt)	Max Current (Amp)	Work with 120 VAC	Work with 240 VAC	Need Neutral?
MKS 670BD21	40	0.3	YES	YES	YES
MKS 670BD21	40	0.3	YES	YES	YES
MKS 670BD21	40	0.3	YES	YES	YES
TPG 361	45	0.38	YES	YES	YES
DCU 600	590	3.8	YES	YES	YES
Lakeshore 218	18	0.15	YES	YES	YES
Lakeshore 218	18	0.15	YES	YES	YES
Lakeshore 218	18	0.15	YES	YES	YES
Lakeshore 218	18	0.15	YES	YES	YES
Keithley 2000	30	0.25	YES	YES	YES
THCD 400	72	0.6	YES	YES	YES
AMI 1700	264	2.2	YES	YES	YES
TOTAL	1193	8.73			

Lifter Control	Max Power (Watt)	Max Current (Amp)	Work with 120 VAC	Work with 240 VAC	Need Neutral?
Motor Power Supply	312	2.6	YES	YES	YES
ADC	USB Powered	USB Powered			
Precision voltage	USB Powered	USB Powered			
TOTAL	312	2.6			

Microwave system	Max Power (Watt)	Max Current (Amp)	Work with 120 VAC	Work with 240 VAC	Need Neutral?
CPI Power Supply	1650	8	NO	YES	NO
Power measurement	104	0.5	YES	NO	YES
EIP freq. counter	100	0.48	YES	YES	YES
DC Power supply	220	1.8	YES	NO	YES
TOTAL	2074	10.78			

Slow Control	Max Power (Watt)	Max Current (Amp)	Work with 120 VAC	Work with 240 VAC	Need Neutral?
USB to Ethernet	10	0.4	YES	NO	YES
USB to Ethernet	10	0.4	YES	NO	YES
USB to Ethernet	10	0.4	YES	NO	YES
USB to Ethernet	10	0.4	YES	NO	YES
USB to Ethernet	10	0.4	YES	NO	YES
RS232 to Ethernet	6.03	0.19	YES	NO	YES
RS232 to Ethernet	6.03	0.19	YES	NO	YES
TOTAL	62.06	2.38			

Other system	Max Power (Watt)	Max Current (Amp)	Work with 120 VAC	Work with 240 VAC	Need Neutral?
Fridge valve	55	0.46	YES	NO	YES
Microwave interlock					
TOTAL	55	0.46-			

Notes: Carlos estimation

Total Consumption

System	Max Power (Watt)	Max Current (Amp)
Cryo Control	1193	8.73
Lifter Control	312	2.6
Microwave system	2074	10.78
Slow Control	62.06	2.38
Other	55	0.46
TOTAL	3696.06	24.95

Devices that require 120 VAC, single phase and require neutral

Devices	Max Power (Watt)	Max Current (Amp)
RF-Power measurement	104	0.5
DC Power supply	220	1.8
USB to Ethernet	10	0.4
USB to Ethernet	10	0.4
USB to Ethernet	10	0.4
USB to Ethernet	10	0.4
USB to Ethernet	10	0.4
RS232 to Ethernet	6.03	0.19
RS232 to Ethernet	6.03	0.19
TOTAL	386.06	4.68

Devices that require 240 VAC, single phase and NO neutral

devices	Max Power (Watt)	Max Current (Amp)
CPI Power Supply	1650	8

Devices that could work both on 120 VAV & 240 VAC, require 1-phase & Neutral

Devices	Max Power (Watt)	Max Current (Amp)
MKS 670BD21	40	0.3
MKS 670BD21	40	0.3
MKS 670BD21	40	0.3
TPG 361	45	0.38
DCU 600	590	3.8
Lakeshore 218	18	0.15
Lakeshore 218	18	0.15
Lakeshore 218	18	0.15
Lakeshore 218	18	0.15
Keithley 2000	30	0.25
THCD 400	72	0.6
AMI 1700	264	2.2
Motor Power Supply	312	2.6
EIP freq. counter	100	0.48
TOTAL	1605	11.81