

NMR Test Setup Manual

USER MANUAL OF NMR TEST SETUP IN THE COUNTING ROOM



Amal Nishantha Pattividana
UNIVERSITY OF VIRGINIA | VA
anpattividana@virginia.edu, anpattividana@gmail.com

Version: 1.0.1
2023-12-14

Introduction

This document includes detailed information of NMR System named NMR2 constructed in NM4 Laboratory, Batavia Fermilab site. The NMR2 is the replication of the portable NMR System already used by Polarized Target Group that is originally designed as smaller, portable, alternative to the Liverpool NMR System already use in Room 28. The NMR2 system is supposed to be used as a testing setup for Polarized Target Group.

The purpose of this manual is to provide an understand of the components and basic operations of the NMR2 system to the users and operators.

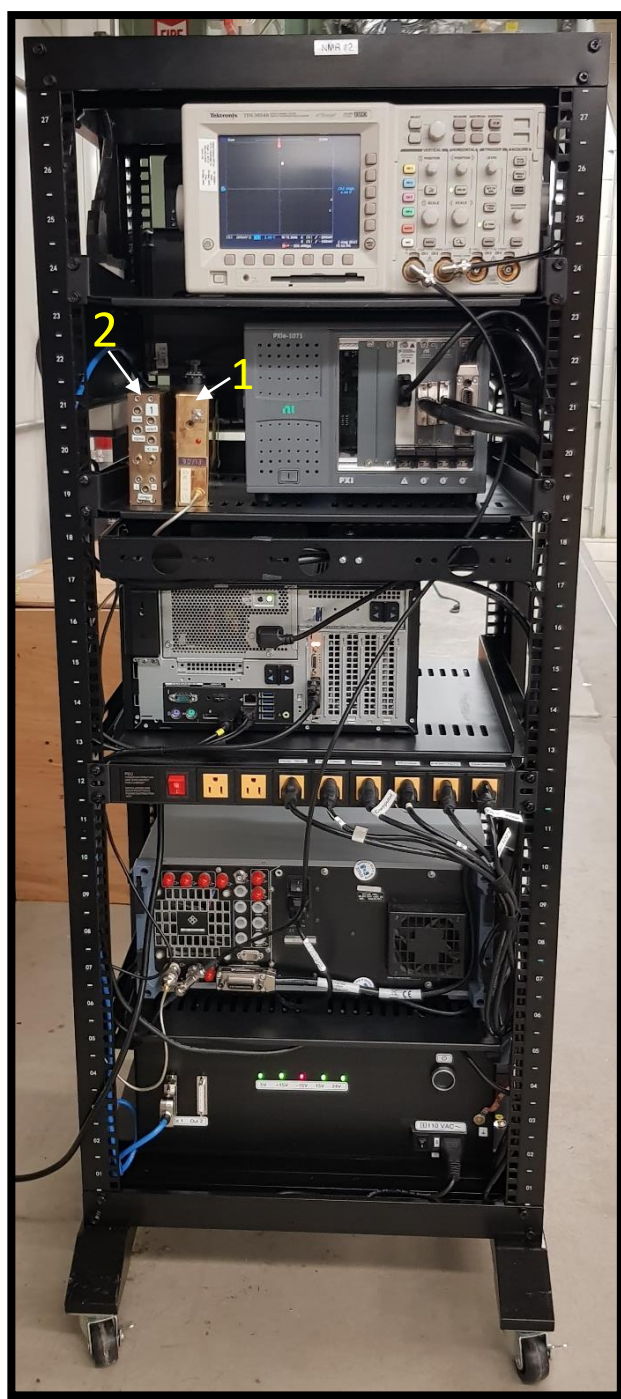
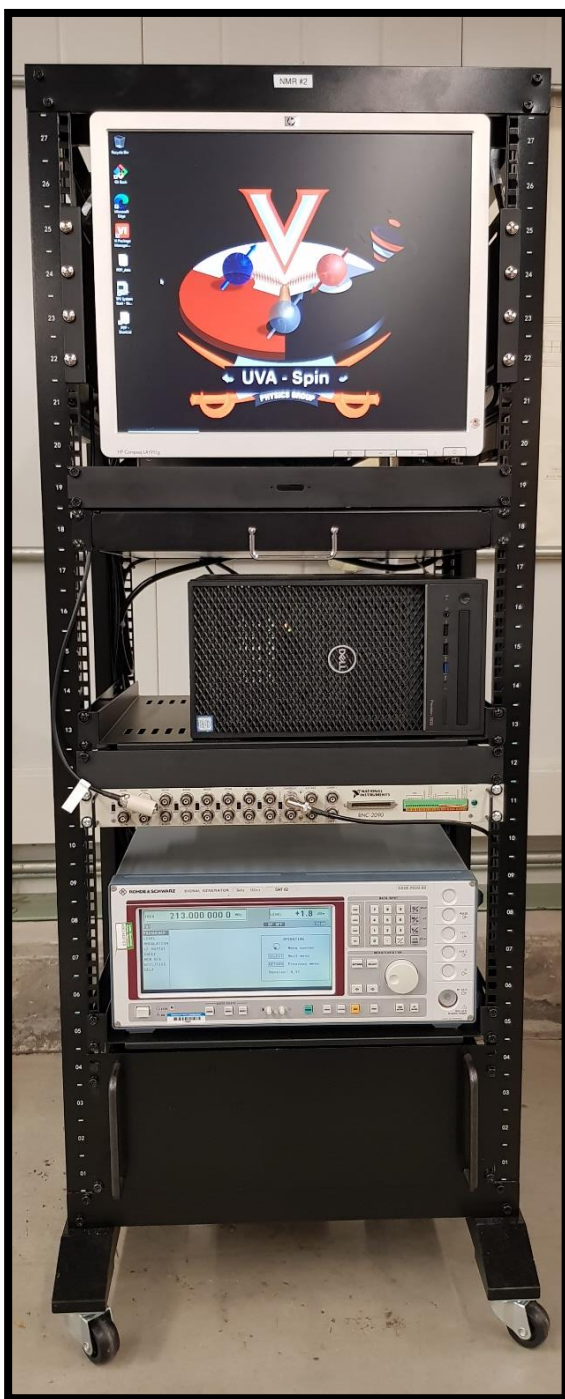

Hardware components

NMR Rack

All the components are mounted in a standard 19" equipment rack that is included with caster wheels for more portability. All 4 sides in the rack are used to mount the required equipment. The following items have been placed and mounted on the Rick. All the components have been described separately in bellow section.

1. HP Monitor with a rack mount bracket.
2. USB Keyboard with a touch pad in a sliding shelf
3. Dell Precision 3650 Computer
4. Tektronix Oscilloscope
5. Connection Box
6. NI BNC 2090
7. Signal Generator
8. NI PXIe-1071 chassis with required cards
9. Q-meter
10. Yale card
11. AC power strip
12. Yale card power supply
13. NI SCB-68A
14. NI BNC-2115

Basic connection diagram of the NMR Rack is given below.

AC / DC Power

Most of the devices are working with AC Main power and power is distributed to all devices through the AC power strip. In the diagram (Figure 1.5), AC power lines are shown with red color. Yale Card required a set of DC voltages that is provided by Yale Card power supply. The DC Power cables are shown in blue color. All the power switches are shown with the  symbol. A red color power switch is available in the AC main power strip, and it controls all the AC power lines. And AC power strip includes the main power code of the NMR2 Setup. The main power should be supplied through a single fused socket outlet.

Ethernet Network

Wired Gigabit Ethernet connection may be provided to the computer. That is allowed to remotely access the computer, Update software and firmware of the system and devices, and browse the internet using computer. The network settings could be configured in windows network settings.

Addition to that, there is another ethernet port in the Oscilloscope that allows you to remote access or access through the PC. The network settings could be configured in oscilloscope settings.

However, the network connection is not required to provide and all other functions of the setup are working without network connection.

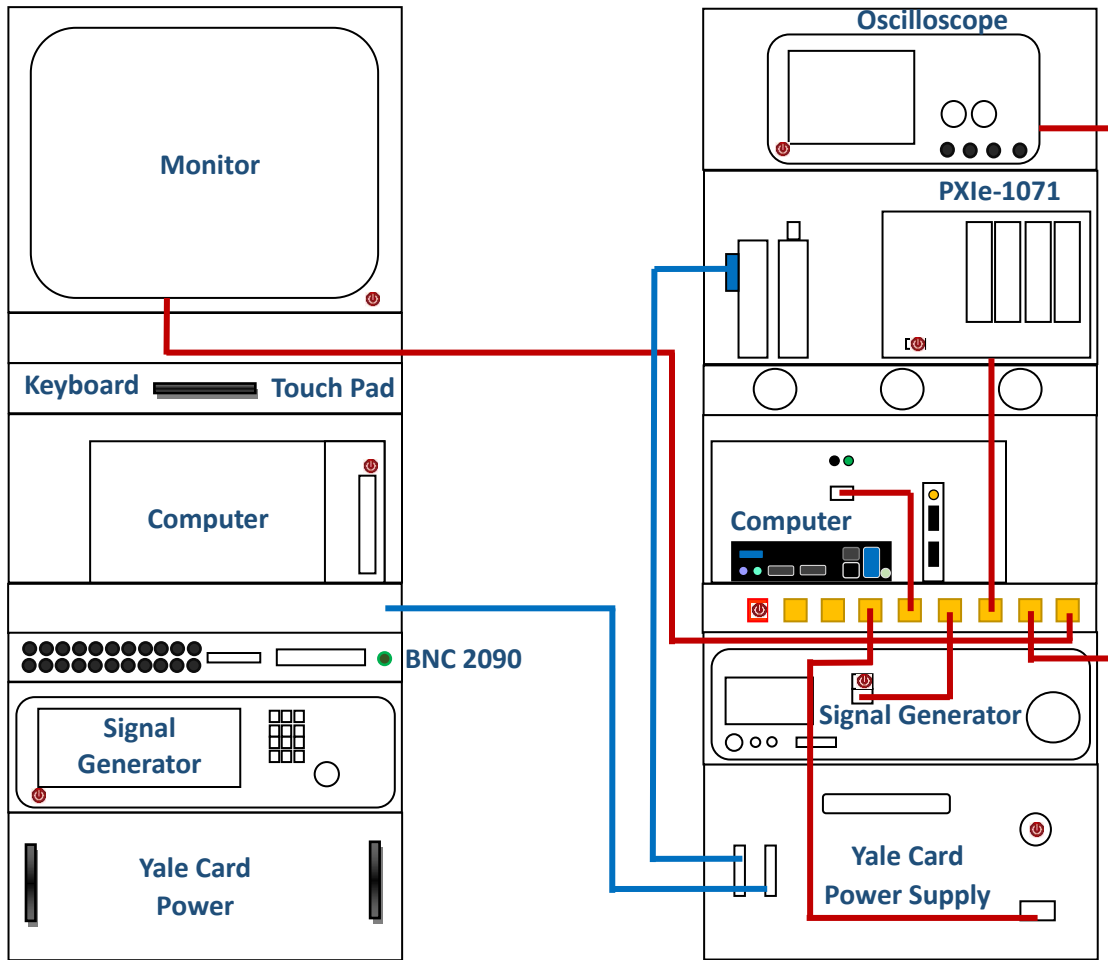

Figure 1.5 - Power Connections of the setup

- 120 VAC
- DC Power bus

Data and Signal Cables

The data wire connections of the NMR2 setup in between the devices is shown in Figure 1.6. The peripherals are connected with several types of data and signal cables. Both power and data/signal wires are available in some cables.

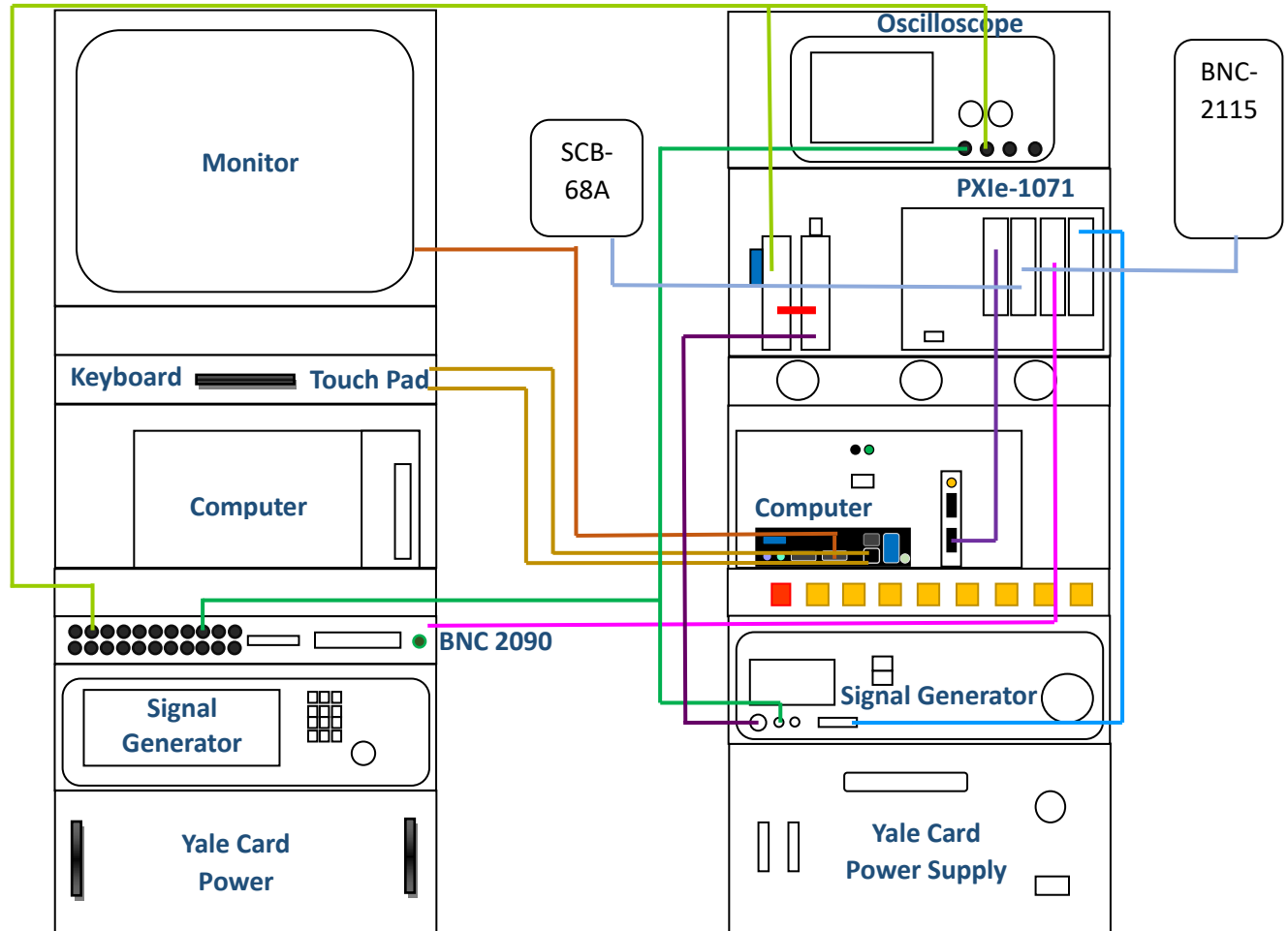











Figure 1.6 - Data Connections of the setup

- | | | | |
|---|---------------------------------|---|--|
|  | BNC Cable with BNC T Connectors |  | BNC Cable with BNC T Connectors |
|  | Display port to DVI-D Connector |  | USB Cables from peripherals |
|  | NI SHC68-68-EPM Cable |  | NI SHC68-68-EPM Cable |
|  | 10833A GPIB Cable |  | NI Cable |
|  | SMA Flexible RF Cable |  | Yale Card – Q-meter Data/Power Connector (Custom made) |

HP Monitor with a rack mount bracket

USB Keyboard with a touch pad in a sliding shelf

Dell Precision 3650 Computer

Tektronix Oscilloscope

Connection Box

NI BNC 2090

Signal Generator